

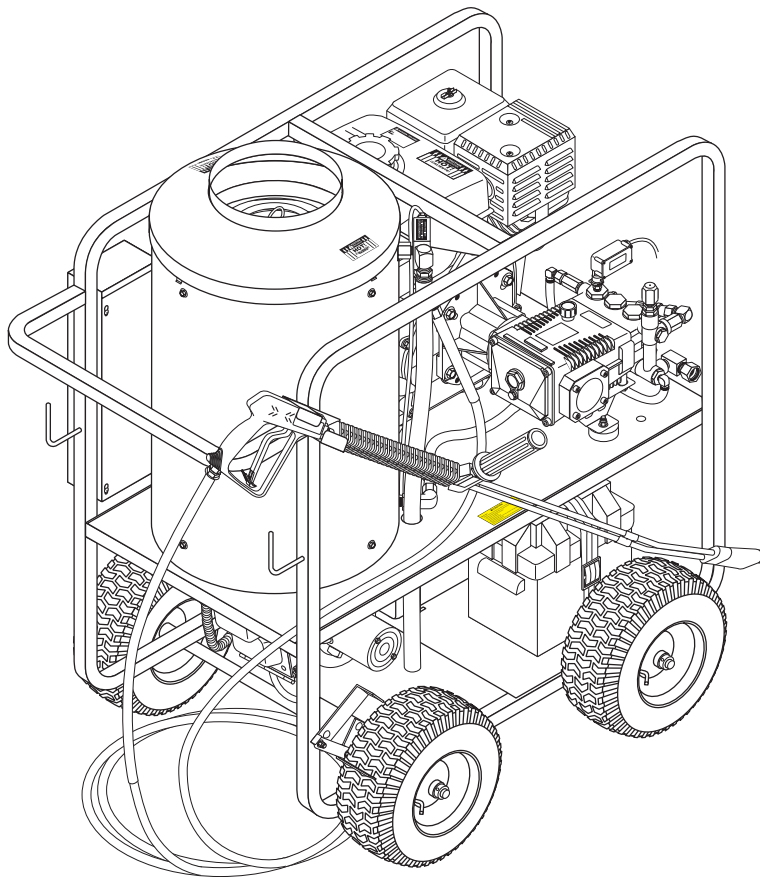

KÄRCHER

OPERATOR'S MANUAL



MODEL HDS 2.5/20 P Cage - 1.575-554.0

MODEL HDS 2.8/25 P Cage - 1.575-555.0

MODEL HDS 2.6/30 P Cage - 1.575-550.0

MODEL HDS 3.5/30 P Cage - 1.575-551.0

MODEL HDS 3.5/30 Pe Cage - 1.575-552.0

MODEL HDS 3.5/35 Pe Cage - 1.575-553.0

To locate your local Kärcher Commercial Pressure Washer Dealer nearest you,
please call 1-888-805-9852 or visit www.karchercommercial.us

9.800-079.0

CONTENTS

Introduction & Important Safety Instructions	4-5
Component Identification	6
Assembly Instructions	7
Operating Instructions	8-9
Detergents and Cleaning Tips	10
Shut-Down and Clean Up	11
Storage	11
Maintenance	12-14
Troubleshooting	15-17
Maintenance & Oil Change Charts	18
Exploded View - 554.0, 555.0	19
Exploded View - 550.0, 551.0, 552.0, 553.0	20-21
Exploded View Parts Lists	22-25
Control Panel - 554.0, 555.0 & Parts List	26-27
Control Panel - 550.0, 551.0, 552.0, 553.0 & Parts List	28-29
Hose & Spray Gun Assembly & Parts List	30
Downstream Injector Assembly	31
Hose Reel Option	32
VBA35 Unloader Exploded View and Parts List	33
KG Pump Exploded View and Parts List	34-35
KG-1 Pump Exploded View and Parts List	36-37
Burner Specifications	38
Warranty	

Model Number _____

Serial Number _____

Date of Purchase _____

The model and serial numbers will be found on a decal attached to the pressure washer. You should record both serial number and date of purchase and keep in a safe place for future reference.

INTRODUCTION & IMPORTANT SAFETY INFORMATION

Thank you for purchasing a Hot Water Pressure Washer.

All information in this manual is based on the latest product information available at the time of printing.

We reserves the right to make changes at any time without incurring any obligation.

This series was designed for maximum use of 4 hours per day, 5 days per week.

Owner/User Responsibility:

The owner and/or user must have an understanding of the manufacturer's operating instructions and warnings before using this pressure washer. Warning information should be emphasized and understood. If the operator is not fluent in English, the manufacturer's instructions and warnings shall be read to and discussed with the operator in the operator's native language by the purchaser/owner, making sure that the operator comprehends its contents.

Owner and/or user must study and maintain for future reference the manufacturers' instructions.

This manual should be considered a permanent part of the machine and should remain with it if machine is resold.

When ordering parts, please specify model and serial number.

IMPORTANT SAFETY INSTRUCTIONS

WARNING: When using this machine basic precautions should always be followed, including the following:



CAUTION: To reduce the risk of injury, read operating instructions carefully before using.

1. Read the owner's manual thoroughly. Failure to follow instructions could cause malfunction and result in death, serious bodily injury and/ or property damage.
2. Know how to stop the machine and bleed pressures quickly. Be thoroughly familiar with the controls.
3. **Stay alert** - watch what you are doing.
4. All installations must comply with local codes. Contact your electrician, plumber, utility company or the selling distributor for specific details.



WARNING: Flammable liquids can create fumes which can ignite causing property damage or severe injury.

5. Risk of explosion - do not spray flammable liquids or operate in an explosive location. Operate only where open flame or torch is permitted.

WARNING: Do not place machine near flammable objects when the engine is hot.



WARNING: Keep water spray away from electrical wiring or fatal electric shock may result.

WARNING: Spray gun kicks back. Hold with both hands.

6. Grip cleaning wand securely with both hands before starting the cleaner. Failure to do this could result in injury from a whipping wand.



WARNING: Risk of fire. Do not add fuel when the machine is operating.

7. Allow engine to cool for 2 minutes before refueling. If any fuel is spilled, make sure area is dry before testing spark plug or starting the engine. (Fire and/or explosion may occur if this is not done.)

Gasoline engines on mobile or portable equipment shall be refueled:

- a. Outdoors;
- b. With the engine on the equipment stopped;
- c. With no source of ignition within 10 feet of the dispensing point;
- d. With an allowance made for expansion of the fuel should the equipment be exposed to a higher ambient temperature.

In an overfilling situation, additional precautions are necessary to ensure that the situation is handled in a safe manner.



WARNING: Risk of injection or severe injury to persons - Keep clear of nozzle - Do not touch or direct discharge stream at persons. This machine is to be used only by trained operators.

CAUTION: Hot discharge fluid. Do not touch or direct discharge stream at persons.

IMPORTANT SAFETY INFORMATION

8. High pressure developed by these machines can cause personal injury or equipment damage. Use caution when operating. Do not direct discharge stream at people, or severe injury and/ or death may result.



WARNING: High pressure can cause paint chips or other particles to become airborne and fly at high speeds.

9. Eye safety devices and foot protection must be worn when using this equipment.
10. Never make adjustments on machine while in operation.



WARNING: Use only in well ventilated areas. Failure to observe this warning could cause a loss of consciousness or death. This machine was designed for outdoor use only. Use high pressure extension hose to clean indoors. Store indoors.

11. Avoid installing in small areas or near exhaust fans. Exhaust contains poisonous carbon monoxide gas; exposure may cause loss of consciousness and may lead to death. It also contains chemicals known, in certain quantities, to cause cancer, birth defects or other reproductive harm.
12. Do not operate with the spray gun in the off position for more than five minutes as this may cause damage to the pump.
13. The best insurance against an accident is precaution and knowledge of the machine.
14. We will not be liable for any changes made to our standard machines, or any components not purchased from us.
15. Read engine safety instructions provided.
16. Never run pump dry or leave spray gun closed longer than 5 minutes.
17. Inlet water must be from a cold, clean fresh city water supply.



WARNING: Only use recommended fuel. Using other fuels may result in a serious explosion causing personal injury, property damage or loss of life.

18. Use No. 1 or No. 2 heating oil (ASTM D306) only. **NEVER** use gasoline in your fuel oil tank. Gasoline is more combustible than fuel oil and could result in a serious explosion. **NEVER** use crankcase or waste oil in your burner assembly. Fuel pump malfunction could result from contamination.
19. Do not confuse gasoline and fuel oil tanks. Keep proper fuel in proper tank.
20. Protect machine from freezing.
21. Be certain all quick coupler fittings are secured before using pressure washer.
22. Do not allow acids, caustic or abrasive fluids to pass through the pump.
23. To reduce the risk of injury, close supervision is necessary when a product is used near children. Do not allow children to operate the pressure washer. **This machine must be attended during operation.**
24. Do not operate this product when fatigued or under the influence of alcohol or drugs. Keep operating area clear of all persons.
25. Protect high pressure hose from vehicle traffic and sharp objects.
26. Before disconnecting high pressure hose from water outlet, turn burner off and pull the trigger on the spray gun allowing water to cool to below 100° F before stopping machine. Then open the spray gun to relieve pressure. Failure to properly cool down or maintain the heating coil may result in a steam explosion and/or heating coil damage.
27. Do not overreach or stand on unstable support. Keep good footing and balance at all times.
28. This machine must be attended during operation.
29. **CAUTION: Risk of injury. Disconnect battery ground terminal before servicing.**
30. **CAUTION: Moving this machine on a slope causes instability and may result in machines tipping over. Use lifting bar provided on the center top of frame.**

COMPONENT IDENTIFICATION

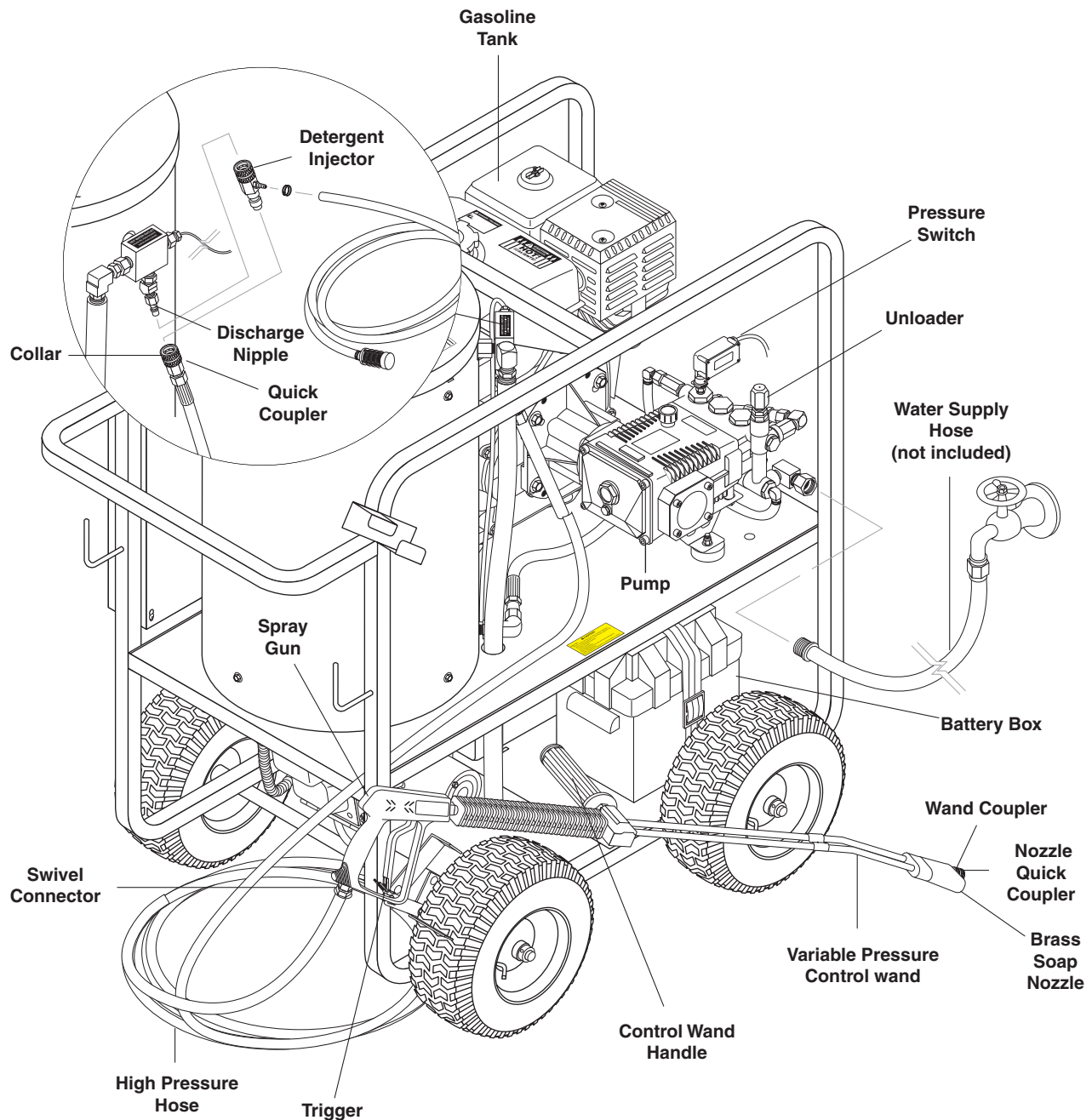

Pump — Develops high pressure.

Starter Grip — (Not Shown) Used for starting the engine manually.

Spray Gun — Controls the application of water and detergent onto cleaning surface with trigger device. Includes safety latch.

Detergent Injector — Allows you to siphon and mix detergents.

Variable Pressure Control Wand — Must be connected to the spray gun. This wand handle controls discharge flow from one tube to both wand tubes. When water is discharged from both tubes you will have a pressure loss and allows chemical siphoning when used in combination with a detergent injector.

High Pressure Hose — Connect one end to water pump discharge nipple and the other end to spray gun.

Note: If trigger on spray gun is released for more than 2 minutes, water will leak from valve. Warm water will discharge from pump protector onto floor. This system prevents internal pump damage.

ASSEMBLY INSTRUCTIONS

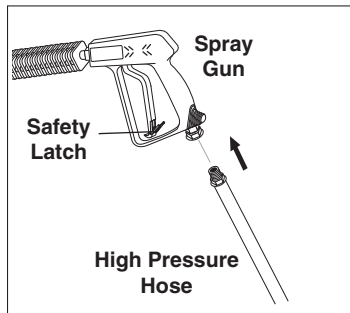

STEP 1: Attach the high pressure hose to the spray gun using teflon tape on hose threads.

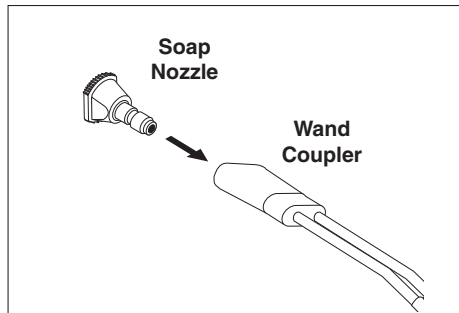

STEP 2: Pull the spring-loaded collar of the wand coupler back to insert your choice of pressure nozzle.

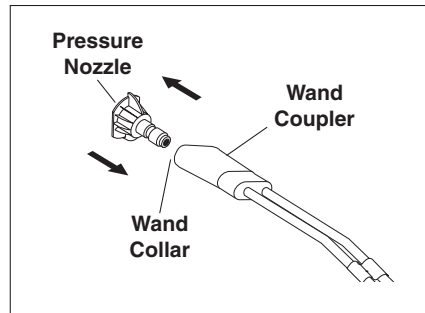

STEP 3: Release the coupler collar and push the nozzle until the collar clicks. Pull the nozzle to make sure it is seated properly.

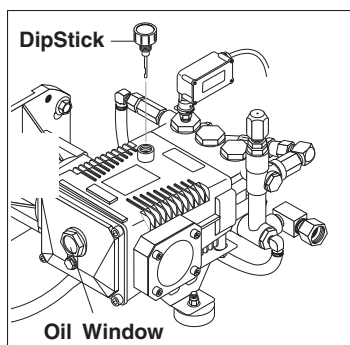

STEP 4: Remove shipping cap and install oil dipstick. Check pump oil level by using dipstick or observe oil level in oil window (if equipped). Use 30 wt. non detergent oil.

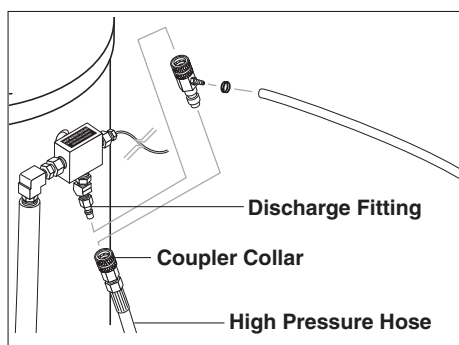

STEP 5: Connect the high pressure hose to the pump discharge fitting. Push coupler collar forward until secure.

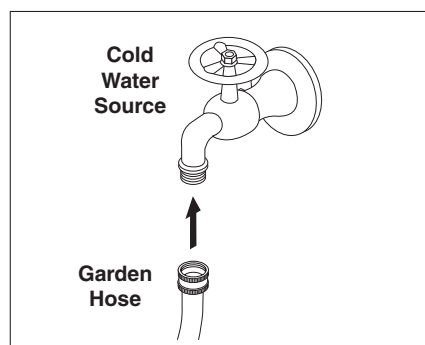

STEP 6: Connect garden hose to the cold water source.

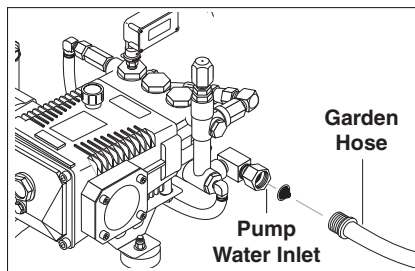

STEP 7: Connect the garden hose to pump water inlet. Inspect inlets. **CAUTION: Do not run the pump without water or pump damage will result.**

OPERATING INSTRUCTIONS

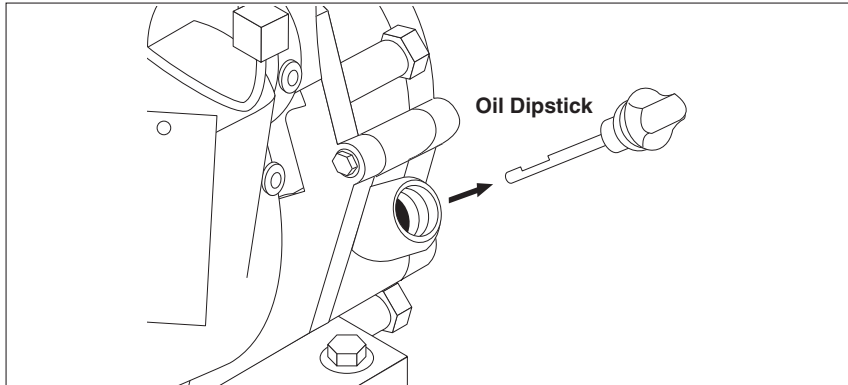

STEP 1: Check engine oil level. Oil level should be level with the bottom of the oil filler neck. Be sure the machine is level when checking the oil level. (Refer to the engine's operating manual included with machine.) We recommend that the oil be changed after the first 5 hours of use, then once every 50 hours. **Note:** Improper oil levels will cause low oil sensor to shut off engine. **IMPORTANT! Do not run engine with high or low oil levels as this will cause engine damage.**

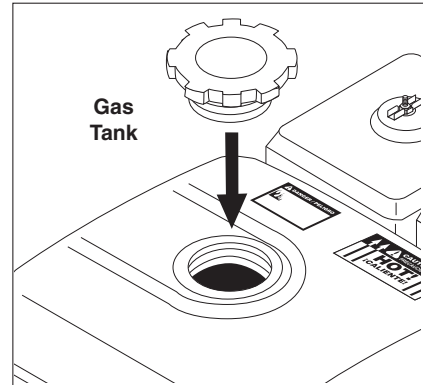

STEP 2: Fill gas tank with unleaded gasoline. Do not use leaded gasoline. **Caution: Read warnings on pg. 4 and engine manual.**

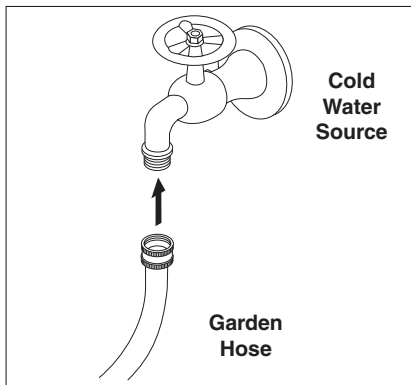

STEP 3: Connect garden hose to the cold water source and turn water on completely. Never use hot water.

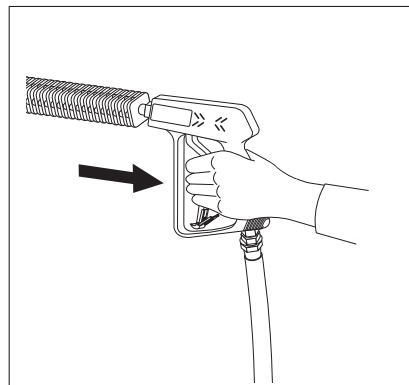

STEP 4: Trigger the spray gun to eliminate trapped air then wait for a steady flow of water to emerge from the spray nozzle.

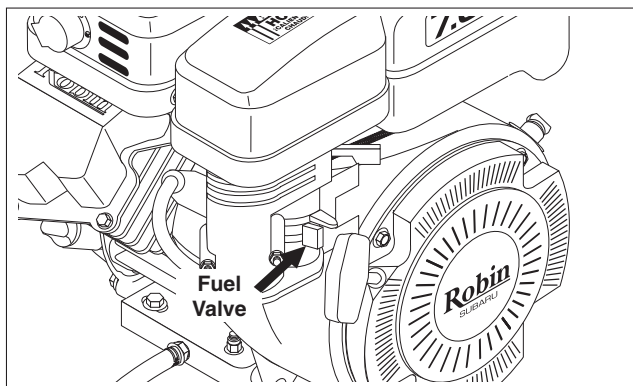

STEP 5: Rotate the fuel shut-off valve to the "On" position. Slide the fuel valve lever to the "ON" position. When the engine is not in use, leave the fuel valve in the "OFF" position.

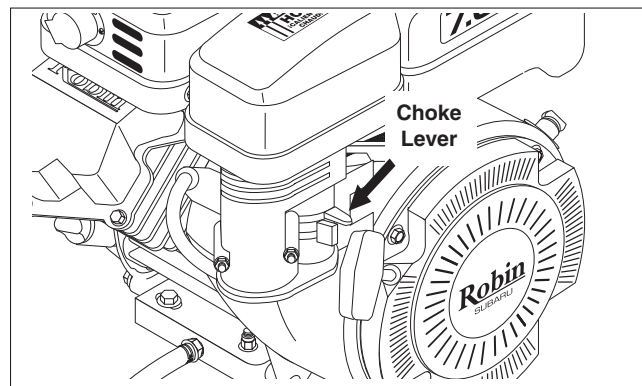

STEP 6: Pull the choke lever out to the "Choke" position (on a warm engine, leave the choke lever in, in the run position). Push the choke lever to the "Closed" position. To restart a warm engine, leave the choke lever in the "Open" position.

OPERATING INSTRUCTIONS

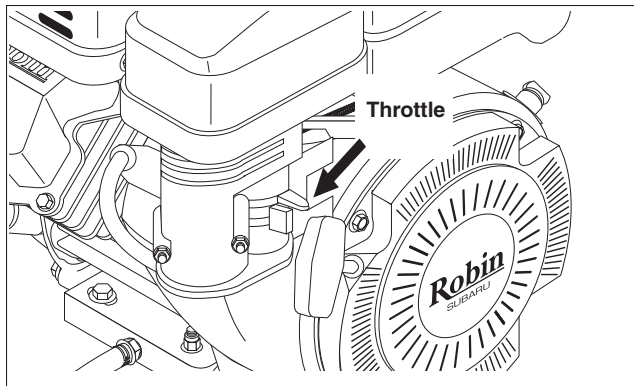

STEP 7: Turn the engine to "Run" position.

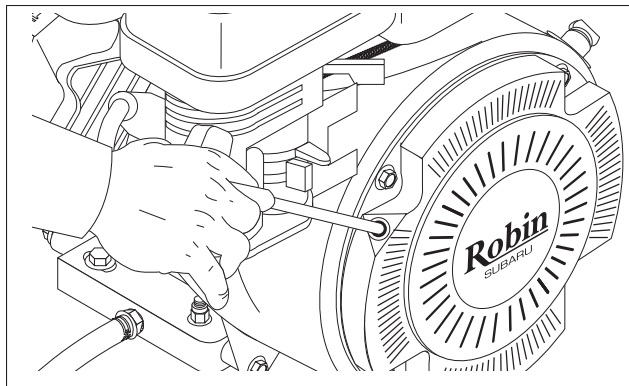

STEP 8: Pull the starter grip. If the engine fails to start after 2 pulls, squeeze the trigger gun to release pressure and repeat step. Return starter gently. After the engine warms up enough to run smoothly, move choke to run position and throttle to fast position.

CAUTION: Small engines may kick back. Do not hold pull starter grip tightly in hand.

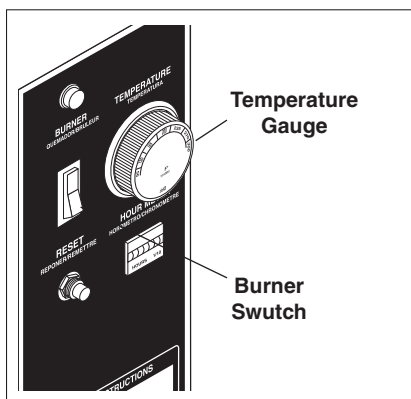

STEP 9: If hot water is required. Adjust temperature gauge to proper temperature (200°). Turn on Burner switch to begin heating water.

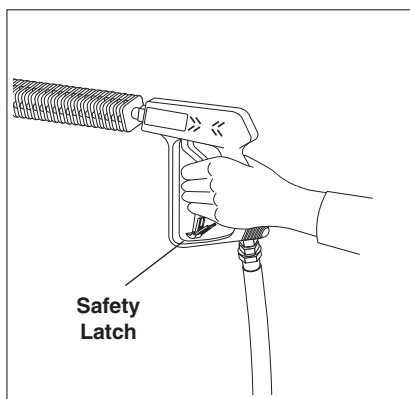

WARNING! Never replace nozzles without engaging the safety latch on the spray gun trigger.

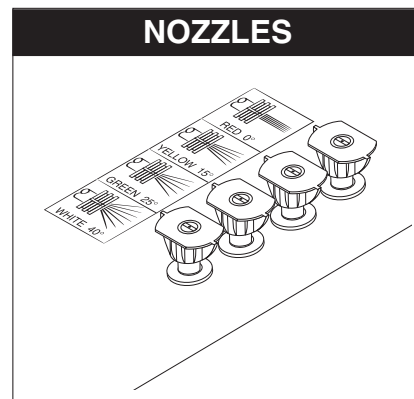

The four color-coded quick connect nozzles provide a wide array of spray widths from 0° to 45° and are easily accessible when placed in the convenient rubber nozzle holder, which is provided on the front of the machine.

NOTE: For a more gentle rinse, select the white 40° or green 25° nozzle. To scour the surface, select the yellow 15° or red 0° nozzle. To apply detergent select the black nozzle.

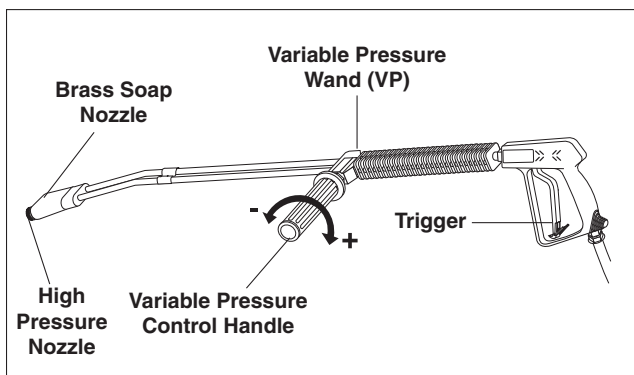

Selection of high or low pressure is accompanied by turning the handle. **NOTE:** High pressure nozzle must be inserted at end of wand to obtain high pressure. To apply soap read operator's manual.

DETERGENTS AND CLEANING TIPS



WARNING

WARNING: Some detergents may be harmful if inhaled or ingested, causing severe nausea, fainting or poisoning. The harmful elements may cause property damage or severe injury.

STEP 1: Connect detergent injector to discharge nipple on machine, Connect high pressure hose to injector with quick coupler (check to make sure locking coupler sleeves are in proper position before applying water pressure

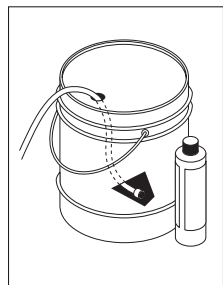
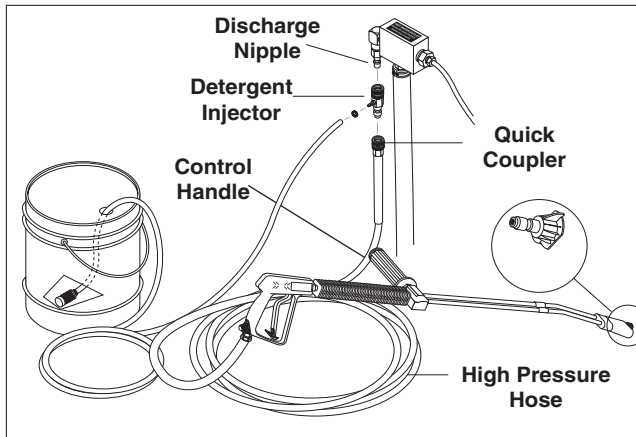

STEP 2: Use detergent designed specifically for pressure washers. Household detergents could damage the pump. Prepare detergent solution as required by the manufacturer. Fill a container with pressure washer detergent. Place the filter end of detergent suction tube into the detergent container.

STEP 3: Apply safety latch to spray gun trigger. Turn variable pressure control handle until discharge water exits both tubes. Secure black detergent nozzle into quick coupler if you have a single wand. **NOTE:** Detergent cannot be applied using Red, Yellow, Green or White nozzles.

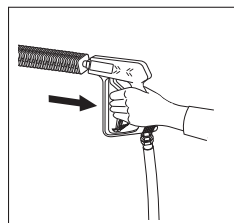

STEP 4: With the engine running, pull trigger to operate machine. Liquid detergent is drawn into the machine and mixed with water. Apply detergent to work area. Do not allow detergent to dry on surface.

IMPORTANT: You must flush the detergent injection system after each use by placing the suction tube into a bucket of clean water, then run the pressure washer in low pressure for 1-2 minutes.

THERMAL PUMP PROTECTION

If you run the engine on your pressure washer for 3-5 minutes without pressing the trigger on the spray gun, circulating water in the pump can reach high temperatures. When the water reaches this temperature, the pump protector engages and cools the pump by discharging the warm water onto the ground. This thermal device prevents internal damage to the pump.

CLEANING TIPS

Pre-rinse cleaning surface with fresh water. Place detergent suction tube directly into cleaning solution and apply to surface at low pressure (for best results, limit your work area to sections approximately 6' square and always apply detergent from bottom to top). Allow detergent to remain on surface 1-3 minutes. Do not allow detergent to dry on surface. If surface appears to be drying, simply wet down surface with fresh water. If needed, use brush to remove stubborn dirt. Rinse at high pressure from top to bottom in an even sweeping motion keeping the spray nozzle approximately 1' from cleaning surface. Use overlapping strokes as you clean and rinse any surface. For best surface cleaning action spray at a slight angle.

Recommendations:

- Before cleaning any surface, an inconspicuous area should be cleaned to test spray pattern and distance for maximum cleaning results.
- If painted surfaces are peeling or chipping, use extreme caution as pressure washer may remove the loose paint from the surface.
- Keep the spray nozzle a safe distance from the surface you plan to clean. High pressure wash a small area, then check the surface for damage. If no damage is found, continue to pressure washing.

CAUTION - Never use:

- Bleach, chlorine and other corrosive chemicals
- Liquids containing solvents (i.e., paint thinners, gasoline, oils)
- Tri-sodium phosphate products
- Ammonia products
- Acid-based products

These chemicals will harm the machine and will damage the surface being cleaned.

RINSING

It will take a few seconds for the detergent to clear. Apply safety latch to spray gun. Remove black soap nozzle from the quick coupler. Select and install the desired high pressure nozzle. **NOTE:** You can also stop detergent from flowing by simply removing detergent siphon tube from bottle.

SHUTTING DOWN AND CLEAN-UP

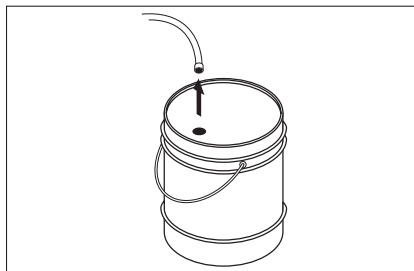

STEP 1: Remove detergent suction tube from container and insert into 1 gallon of fresh water. Turn variable pressure wand handle for low pressure or connect the black detergent nozzle. Pull trigger on spray gun and siphon water for one minute.

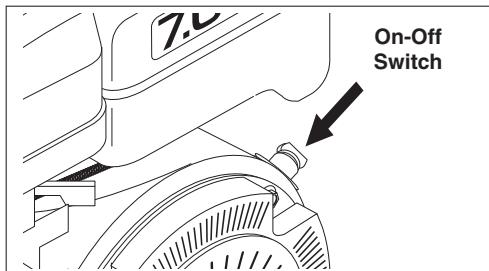

STEP 2: Turn off the engine.

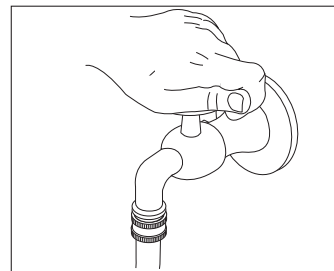

STEP 3: Turn off water supply.

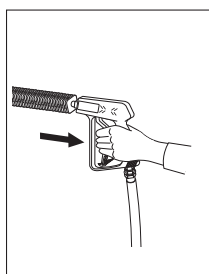

STEP 4: Press trigger to release water pressure.

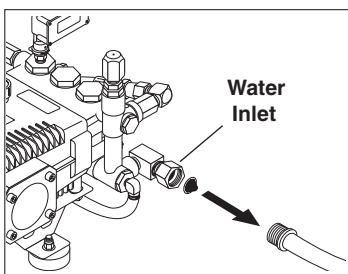

STEP 5: Disconnect the garden hose from the water inlet on the machine.

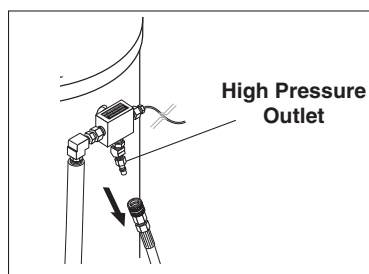

STEP 6: Disconnect the high pressure hose from high pressure outlet.

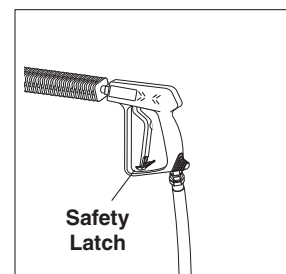

STEP 7: Engage the spray gun safety lock.

STORAGE

CAUTION: Always store your pressure washer in a location where the temperature will not fall below 32°F (0°C). The pump in this machine is susceptible to permanent damage if frozen. **FREEZE DAMAGE IS NOT COVERED BY WARRANTY.**

1. Stop the pressure washer, squeeze spray gun trigger to release pressure.
2. Detach water supply hose and high pressure hose.
3. Turn on the machine for a few seconds, until remaining water exits. Turn engine off immediately.
4. Drain the gas and oil from the engine.
5. Do not allow high pressure hose to become kinked.
6. Store the machine and accessories in a room which does not reach freezing temperatures.

CAUTION: Failure to follow the above directions will result in damage to your pressure washer.

When the pressure washer is not being operated or is being stored for more than one month, follow these instructions:

1. Replenish engine oil to upper level.
2. Drain gasoline from fuel tank, fuel line, fuel valve and carburetor.
3. Pour about one teaspoon of engine oil through the spark plug hole, pull the starter grip several

times and replace the plug. Then pull the starter grip slowly until you feel increased pressure which indicates the piston is on its compression stroke and leave it in that position. This closes both the intake and exhaust valves to prevent rusting of cylinder.

4. Cover the pressure washer and store in a clean, dry place that is well ventilated away from open flame or sparks. **NOTE:** The use of a fuel additive, such as STA-BIL®, or an equivalent, will minimize the formulation of fuel deposits during shortage. Such additives may be added to the gasoline in the fuel tank of the engine, or to the gasoline in a storage container.

After Extended Storage



CAUTION: Prior to restarting, thaw out any possible ice from pressure washer hoses, spray gun or wand.

Engine Maintenance

During the winter months, rare atmospheric conditions may develop which will cause an icing condition in the carburetor. If this develops, the engine may run rough, lose power and may stall. This temporary condition can be overcome by deflecting some of the hot air from the engine over the carburetor area. **NOTE:** Refer to the engine manufacturer's manual for service and maintenance of the engine.

MAINTENANCE

PREVENTATIVE MAINTENANCE

1. Check to see that the water pump is properly lubricated.
2. Follow Winterizing Procedures to prevent freeze damage to the pump and coils.
3. Always neutralize and flush detergent from system after use.
4. If water is known to be high in mineral content, use a water softener in your water system or de-scale as needed.
5. Do not allow acidic, caustic or abrasive fluids to be pumped through system.
6. Always use our high grade quality cleaning products.
7. Never run pump dry for extended periods of time.
8. Use clean fuel: kerosene, No. 1 fuel oil or diesel. Replace fuel filter every 100 hours of operation. Avoid water contaminated fuel as it will seize up the fuel pump.
9. If machine is operated with smoking or eye burning exhaust, coils will soot up, not letting water reach maximum operating temperature. (See section on Air Adjustments.)
10. Never allow water to be sprayed on or near engine or burner assembly or any electrical component.
11. Periodically delime coils as per instructions.
12. Check to see that engine is properly lubricated.

It is advisable, periodically, to visually inspect the burner. Check air inlet to make sure it is not clogged or blocked. Wipe off any oil spills and keep this equipment clean and dry.

The areas around the pressure washer should be kept clean and free of combustible materials, gasoline and other flammable vapors and liquids.

The flow of combustion and ventilating air to the burner must not be blocked or obstructed in any manner. Consult factory if vent stacking is going to be used.

MAINTENANCE AND SERVICE

Unloader Valves:

Unloader valves are preset and tested at the factory before shipping. Occasional adjustment of the unloader may be necessary to maintain correct pressure. Call your local dealer for assistance.

Winterizing Procedure:

Damage due to freezing is not covered by warranty. Adhere to the following cold weather procedures whenever the washer must be stored or operated outdoors under freezing conditions.

During winter months, when temperatures drop below 32°F, protecting your machine against freezing is necessary. Store the machine in a heated room. If this is not possible then mix a 50/50 solution of anti-freeze/water into a 5 gallon bucket. Place a short section of garden hose into the bucket and connect it to the machine. Elevate the bucket and turn the pump on to siphon the anti-freeze through the machine. If compressed air is available, an air fitting can be screwed into the inlet connector and, by injecting compressed air, all water will be blown out of the system.

High Limit Hot Water Thermostat:

For safety, each machine is equipped with a high limit control switch. In the event that the temperature of the water should exceed its operating temperature, the high limit control will turn the burner off until the water cools.

Pumps:

Use only SAE 30W non-detergent oil. Change oil after the first 50 hours of use. Thereafter, change the oil every three months or at 500 hour intervals. Oil level should be checked by using the dipstick found on top of the pump or the red dot visible through the oil gauge window. Oil should be maintained at that level.

Cleaning of Coils:

In alkaline water areas, lime deposits can accumulate rapidly inside the coil pipes. This growth is increased by the extreme heat build up in the coil. The best prevention for liming conditions is to use high quality cleaning detergents. In areas where alkaline water is an extreme problem, periodic use of our Deliming Powder (part #9-028008) will remove lime and other deposits before coil becomes plugged. (See Deliming Instructions for use of Deliming Powder.)

Deliming Coils:

Periodic flushing of coils is recommended.

1. Fill a container or optional float tank with 4 gallons of water, then add 1 lb. of deliming powder. Mix thoroughly.
2. Remove wand assembly from spray gun and put spray gun into container. Secure the trigger on the spray gun into the open position.
3. Attach a short section (3-5 ft.) of garden hose to machine to siphon solution from an elevated container. Turn pump switch on, allowing solution to be pumped through coils back into the container. Solution should be allowed to circulate 2-4 hours.
4. After circulating solution flush entire system with fresh water. Reinstall wand assembly to spray gun.

Rupture Disk:

If pressure from pump or thermal expansion should exceed safe limits, the rupture disk will burst allowing high pressure to be discharged through hose to ground. When disk ruptures it will need to be replaced. The replacement rupture disk should be torqued to 35 ft. lbs.

Fuel:

Use clean fuel oil that is not contaminated with water and debris. Replace fuel filter and drain tank every 100 hours of operation.

Use No. 1 or No. 2 Heating Oil (ASTM D306) only. **NEVER** use gasoline in your burner tank. Gasoline is more combustible than fuel oil and a serious explosion could result. **NEVER** use crankcase or waste oil in your burner. Fuel unit malfunction could result from contamination.

Fuel Control System:

These machines utilize a fuel solenoid valve located on the fuel pump to control the flow of fuel to the combustion chamber. This solenoid valve, which is normally closed, is activated by a flow switch when water is flowing through it. When an operator releases the trigger on the spray gun, the flow of water through the flow switch stops, turning off the current to the fuel solenoid. The solenoid then closes, shutting off the supply of fuel to the combustion chamber. Controlling the flow of fuel in this way allows for an instantaneous burn or no burn situation, thereby eliminating high and low water temperatures, and combustion smoke normally associated with machines incorporating a spray gun.

CAUTION: Periodic inspection is recommended to insure that the fuel solenoid valve functions properly. This can be done by operating the machine and checking to see that when the trigger on the spray gun is in the off position, the burner is not firing.

Electrode Setting:

(See illustration below.)

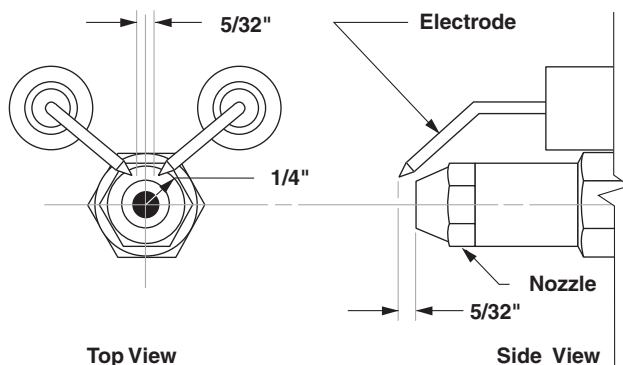

Periodically check wiring connections. If necessary to adjust electrodes, use diagram.

Burner Nozzle:

Keep the tip free of surface deposits by wiping it with a clean, solvent-saturated cloth, being careful not to plug or enlarge the nozzle. For maximum efficiency, replace the nozzle each season.

Air Adjustment:

Machines are preset and performance tested at the factory - elevation 100 feet. A one-time initial correction for your location will pay off in economy, performance and extended service life. If a smoking or eye-burning exhaust is being emitted from the stack, two things should be checked. First, check the fuel to be certain that kerosene or No. 1 home heating fuel is being used. Next, check the air adjustment on the burner.

To adjust: Start machine and turn burner ON. Loosen two locking screws found in the air shutter openings (refer to illustration below) and close air shutter until black smoke appears from burner exhaust vent. Note air band position. Next, slowly open the air shutter until white smoke just starts to appear. Turn air shutter half-way back to the black smoke position previously noted. Tighten locking screws.

If the desired position cannot be obtained using only the air shutter, lock the air shutter in as close a position as can be obtained, then repeat the above procedure on the air band setting.

FUEL AIR ADJUSTMENT

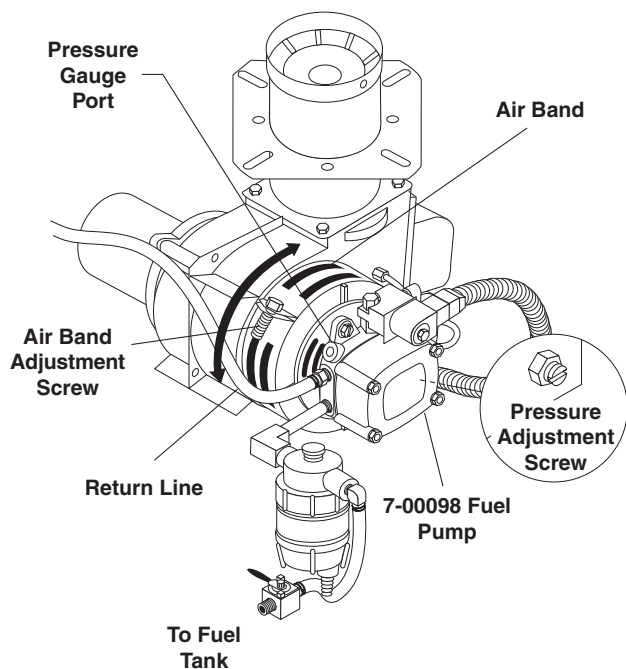

MAINTENANCE

Fuel Pressure Adjustment:

To adjust fuel pressure, turn the adjusting screw clockwise to increase, counterclockwise to decrease. Do not exceed 200 psi. **NOTE:** When changing the fuel pump, a bypass plug must be installed in the return port or the fuel pump will not prime.

Removal of Soot and Heating Coil:

In the heating process, fuel residue in the form of soot deposits may develop on the heating coil and block air flow which will affect burner combustion. When soot has been detected on visual observation, the soot on the coil must be washed off after following the coil removal steps.

1. Remove the tank head assembly by lifting the tank head off.
2. Remove the two pipe nipples and associated fittings.
3. Lift the coil out of the outer wrap.

CAUTION: *The coil weighs about 80 lbs. Use proper lifting techniques.*

4. Clean, repair and replace the coil by reversing the above steps.

Coil Reinstallation:

Reinstall by reversing the above steps 4 through 1.

Final Note:

The 12 VDC burner systems can draw as much as 18 amps! For such burners to run properly, the battery and engine charging system must be kept in good condition. The engine must run at the correct RPM to adequately charge the battery. It is equally important not to throttle down the engine on models without batteries, since all power to run the burner comes solely from the engine. Do not throttle down the engine at anytime while the machine is operating.

TROUBLESHOOTING

PROBLEM	POSSIBLE CAUSE	SOLUTION
LOW OPERATING PRESSURE	Water supply is insufficient	Use larger supply hose; clean filter at water inlet.
	Spray nozzle is old, worn or incorrect	Match the nozzle number to the machine and/or replace with new nozzle.
	Belt slips	Tighten or replace belt; use correct belt.
	Plumbing or hose is leaking	Check plumbing system for leaks. Retape leaks with teflon tape.
	Unloader is faulty or misadjusted	Adjust unloader for proper pressure. Install repair kit when necessary or replace.
	Packing in pump is worn	Install new packing kit.
	Discharge valve in pump or inlet is fouled or dirty	Check inlet and discharge valve.
	Discharge valve or inlet is worn	Replace with valve kit.
	Spray nozzle has obstruction	Remove obstruction.
	Steam pressure control valve is leaking (where applicable)	Rebuild or replace as necessary.
	Engine RPM is slow	Set engine speed at proper specifications / see serial plate.
BURNER WILL NOT LIGHT	There is little or no fuel	Fill tank with fuel.
	Improper fuel or water in fuel	Drain fuel tank and fill with proper fuel.
	Fuel line is clogged	Clean or replace fuel line.
	Fuel filter is plugged	Replace fuel filter as needed.
	Burner air bands are misadjusted	Readjust air bands for clean burn.
	Little or no fuel pressure from fuel pump	Increase fuel pressure to specification and/or replace fuel pump.
	Burner transformer is faulty	Test transformer for proper arc between contacts. Replace as needed.
	Electrical wiring is disconnected or has short in it	All wire contacts should be clean and tight with no breaks in wire.
	Flex coupling is slipping on fuel pump shaft or burner motor shaft	Replace if needed.
	ON-OFF switch is defective	Check for electrical current reaching burner assembly with burner switch on. Replace switch if needed.
	Heavy sooting on coil and burner can cause interruption of air flow and shorting of electrodes	Clean as required.
	Electrode setting is improper	Check and reset according to diagram in manual.
	25 amp circuit breaker tripped	Push in reset button.
	Bridge rectifier defective	Test and replace.
	12V DC relay defective	Test and replace.
Fuel is not reaching combustion chamber	Check fuel pump for proper flow. Check solenoid flow switch on machines with spray gun control for proper on-off flow control.	

TROUBLESHOOTING

PROBLEM	POSSIBLE CAUSE	SOLUTION
BURNER WILL NOT LIGHT (continued from previous page)	Burner nozzle is clogged	Clean as required.
	Thermostat has malfunctioned	Test and replace if needed.
	Fuel solenoid has malfunctioned	Test and replace if needed.
MACHINE SMOKES	Fuel is improper or water is in fuel	Drain tank and replace contaminated fuel.
	Air adjustment is improper	Readjust air bands on burner assembly.
	Fuel pressure is low	Adjust fuel pump pressure to specifications.
	Burner nozzle is plugged or dirty	Replace nozzle. Check parts breakdown for nozzle size.
	Burner nozzle spray pattern is faulty	Replace nozzle. Check parts breakdown for nozzle size.
	Coil and burner assembly have heavy accumulation of soot	Remove coils and burner assembly, clean thoroughly. Call local dealer.
	Electrode setting is misaligned	Realign electrodes to specifications.
	Smoke stack has obstruction	Check for blockage or other foreign objects.
	Engine RPM is low	Increase RPM to correct specs. See serial plate.
LOW WATER TEMPERATURE	Fuel is improper or has water in it	Replace with clean and proper fuel.
	Fuel pressure is low	Increase fuel pressure.
	Fuel pump is weak	Check fuel pump pressure. Replace pump if needed.
	Fuel filter is partially clogged	Replace as needed.
	Soot buildup on coils is not allowing heat transfer	Clean coils.
	Burner nozzle is improper	Call your local dealer for proper nozzle.
WATER TEMPERATURE TOO HOT	Incoming water to machine is warm or hot	Lower incoming water temperature.
	Fuel pump pressure is too high	Call your local dealer for proper fuel pressure.
	Fuel pump is defective	Replace fuel pump.
	Fuel nozzle is incorrect size	See parts breakdown or serial plate for proper size.
	Water supplied is insufficient	Check water GPM to machine.
	Water flow is restricted	Check nozzle for obstruction and proper size. Check serial plate for correct size.
PRESENCE OF WATER IN OIL	Oil seal is worn	Check and replace if necessary.
	Air humidity is high	Check and change oil twice as often.
	Packing is worn or bad	Check and replace if necessary.

TROUBLESHOOTING

PROBLEM	POSSIBLE CAUSE	SOLUTION
DETERGENT NOT DRAWING	Air is leaking	Tighten all clamps. Check detergent lines for holes.
	Injector head may be blocked, dirty or damaged	Clean and make sure ball and spring behind detergent hose barb or injector body are working properly.
	Filter screen on detergent suction hose is plugged	Clean or replace.
	Detergent has high viscosity	Dilute detergent to specifications.
	Not using soap nozzle	Insert soap nozzle into wand coupler.
	Detergent level is low	Add detergent if needed.
PUMP RUNNING NORMALLY BUT PRESSURE LOW ON INSTALLATION	Pump is sucking air	Check water supply and possibility of air seepage.
	Valves are sticking	Check and clean or replace if necessary.
	Unloader valve seat is faulty	Check and replace if necessary.
	Nozzle sized incorrectly	Check and replace if necessary (see serial plate for proper size).
	Packing piston is worn	Check and replace if necessary.
FLUCTUATING PRESSURE	Valves are worn	Check and replace if necessary.
	Valve has a blockage	Check and replace if necessary.
	Pump is sucking air	Check water supply and air seepage at joint in suction line.
	Packing piston is worn	Check and replace if necessary.
PUMP NOISY	Air is in suction line	Check water supply and connections on suction line.
	Inlet or discharge valve springs are weak or broken	Check and replace if necessary.
	Excessive matter is in valves	Check and replace if necessary.
	Bearings are worn	Check and replace if necessary.
WATER DRIPPING FROM UNDER PUMP	Piston packing is worn	Check and replace if necessary.
	O-Ring plunger retainer is worn	Check and replace if necessary.
	Piston is cracked	Check and replace if necessary.
	Pump protector is worn	Lower water supply pressure. Do not run the spray gun closed longer than 5 minutes.
OIL DRIPPING	Oil seal is worn	Check and replace if necessary.
EXCESSIVE VIBRATION IN DELIVERY LINE	Valves are functioning irregularly	Check and replace if necessary.
BURNER MOTOR WILL NOT RUN	Fuel pump has seized	Replace fuel pump.
	Burner fan loose or misaligned	Position correctly and tighten set screw.
	Control switch is defective	Replace switch.
	There is a loose wire	Check and replace or tighten wiring.
	Burner motor is defective	Replace motor.
RELIEF VALVE LEAKS WATER	Relief valve is defective	Replace or repair relief valve.

MAINTENANCE CHARTS

PREVENTATIVE MAINTENANCE

This pressure washer was produced with the best available materials and quality craftsmanship. However, you as the owner have certain responsibilities for the correct care of the equipment. Attention to regular preventative maintenance procedures will assist in preserving the performance of your equipment. Contact your dealer for maintenance. Regular preventative maintenance will add many hours to the life of your pressure washer. Perform maintenance more often under severe conditions.

MAINTENANCE SCHEDULE		
Engine Oil	Inspect	Daily
	Change	Every 25 hours
	Filter	Every 50 hours
Air Cleaner	Inspect	Every 50 hours or monthly
	Clean	Every 3 months
Battery Level		Check monthly
Engine Fuel Filter		500 hours or 6 months
Spark Plug Maintenance		500 hours or 6 months
Clean Fuel Tank(s)		Annually
Replace Fuel Lines		Annually
Pump Oil	Inspect	Oil level daily
	Change	After first 50 hours, then every 500 hours or annually
Clean Burner Filter		Monthly (More often if fuel quality is poor)
Remove Burner Soot		Annually
Burner Adjustment/Cleaning		Annually
Replace Burner Nozzle		Annually
Descale Coil		Annually (more often if required)
Replace High Pressure Hose		Every 6 months
Replace Quick Couplers		Annually
Clean Water Screen/Filter		Weekly
Replace HP Hose		Annually (if there are any signs of wear)

OIL CHANGE RECORD

Date Oil Changed Month/Day/Year	Estimated Operating Hours Since Last Oil Change	Date Oil Changed Month/Day/Year	Estimated Operating Hours Since Last Oil Change

EXPLODED VIEW - 554.0, 555.0 MODELS

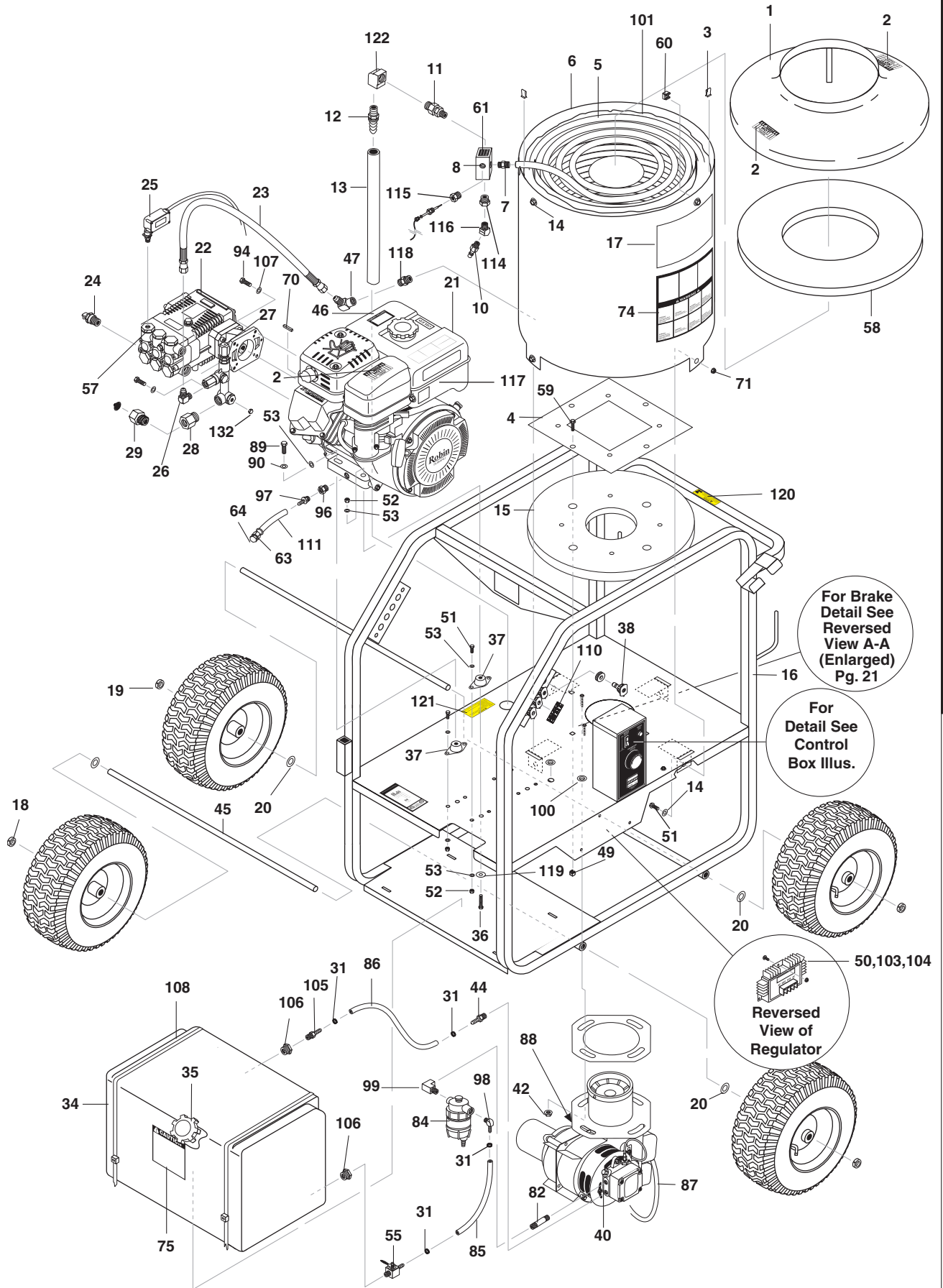

For Brake Detail See Reversed View A-A (Enlarged) Pg. 21

For Detail See Control Box Illus.

Reversed View of Regulator

EXPLODED VIEW - 550.0, 551.0, 552.0, 553.0 MODELS

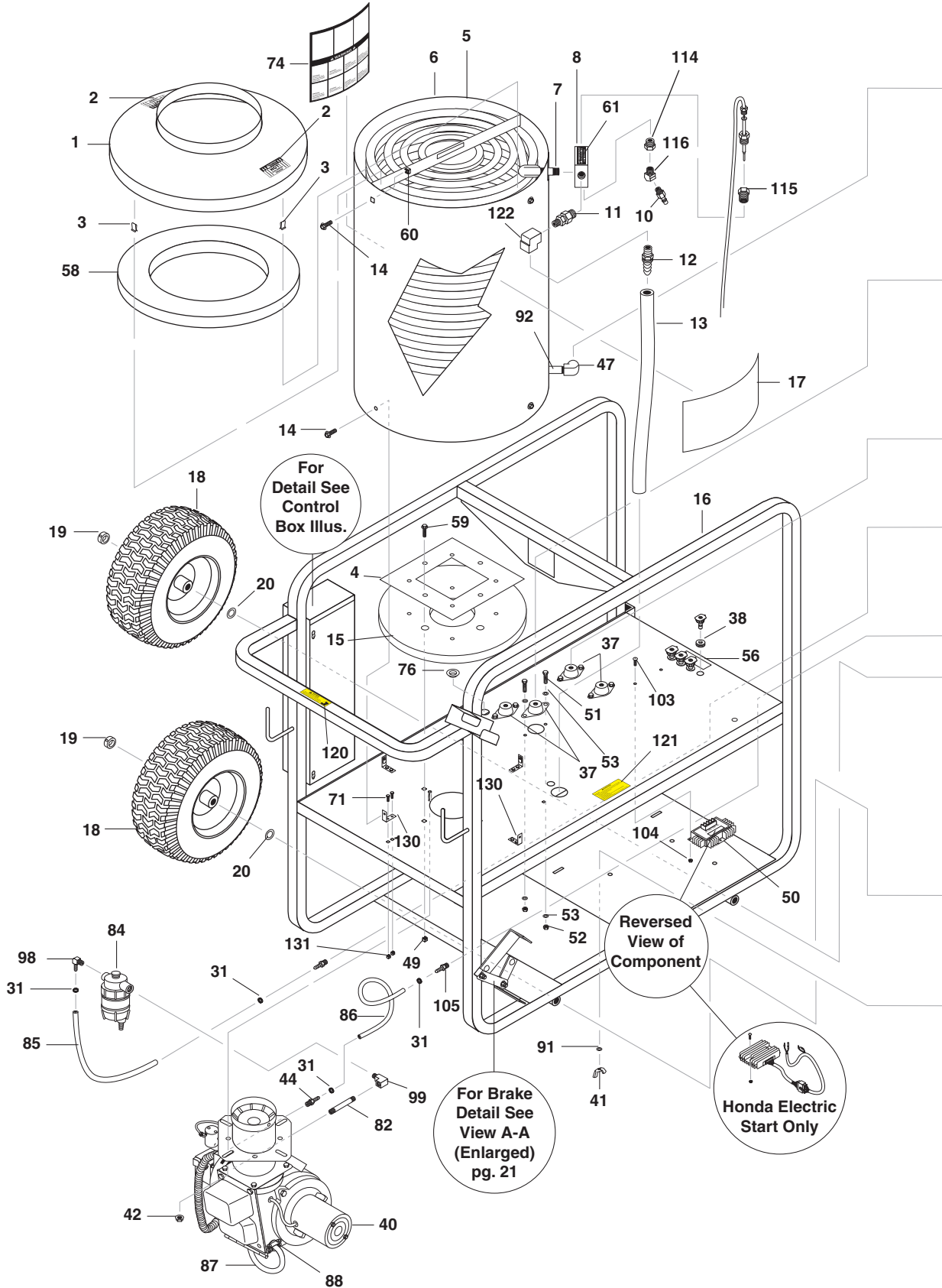

EXPLODED VIEW - 550.0, 551.0, 552.0, 553.0 MODELS

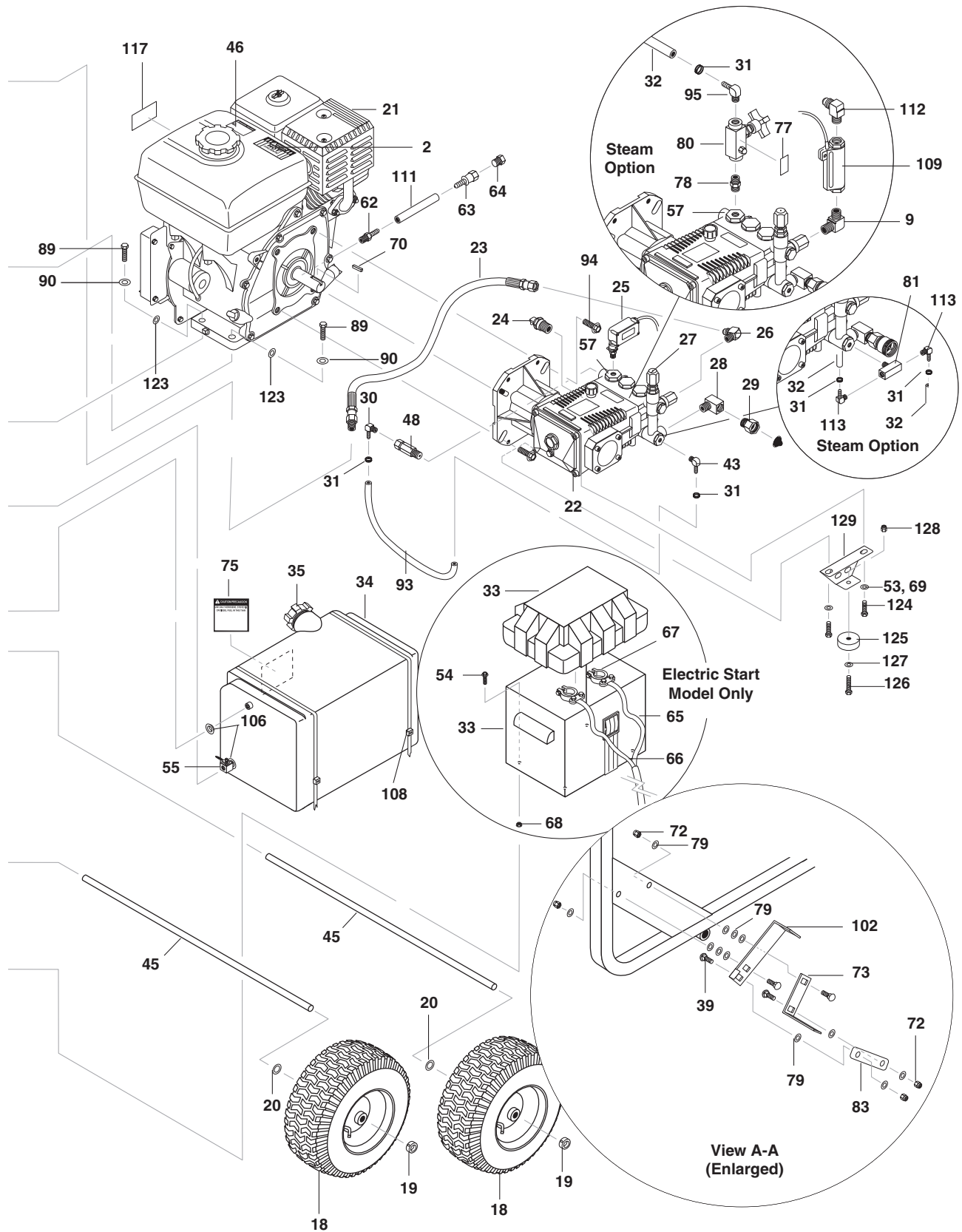

EXPLODED VIEWS PARTS LIST

ITEM	PART NO.	DESCRIPTION	QTY
1	9.803-029.0	Tank Head Assembly, 16" Diameter x 8" Stack	1
2	9.800-006.0	Label, Hot/Caliente w/Arrows Warning	3
3	9.802-825.0	Clip, Retaining, U-Type	4
4	9.803-030.0	Retainer, Burner Insulation	1
5	9.803-134.0	Coil, Dura, 14.5" Dia., Sch 80 (550.0, 551.0, 552.0, 553.0)	1
	9.803-095.0	Coil Assembly (554.0, 555.0)	1
6	9.803-027.0	Wrap, Outer Coil, SS (550.0, 551.0, 552.0, 553.0)	1
	9.804-031.0	Wrap, Outer Coil (554.0, 555.0)	1
7	9.802-012.0	Nipple, 1/2" x M x M, Hex (554.0, 555.0)	1
	9.802-013.0	Nipple 2-1/2" x 1/2", Pipe (550.0, 551.0, 552.0, 553.0)	1
8	9.802-871.0	Block, Discharge, 1/2" x 1/2", Brass	1
9	9.803-044.0	Elbow, 3/8" Male Pipe, (Steam Option)	1
10	9.802-171.0	Nipple, 3/8" x 3/8" NPT ST Male	1
11	9.802-192.0	Disk, Rupture Assy, 7000 PSI	1
12	9.802-156.0	Hose Barb, 1/2" Barb x 3/8" MPT, Push-On	1
13	9.802-259.0	Hose, 1/2" Push-On, Conduit	2.5 ft.
14	9.802-753.0	Screw, 1/4" x 3/4" HH NC (550.0, 551.0, 552.0, 553.0)	9
		(554.0, 555.0)	8
15	9.802-900.0	Insulation, Tank Bottom, 1" Blanket	1
16	9.803-069.0	Assembly, Frame, Large (550.0, 551.0, 552.0, 553.0)	1
	9.803-120.0	Assembly, Frame, Small (554.0, 555.0)	1
17	9.800-110.0	Label, Die-Cut	2
18	9.802-271.0	Wheel & Tire, 6" Steel Rim	4
19	9.802-782.0	Collar, 5/8" Bore Shaft	4
20	9.802-810.0	Washer, 5/8", Flat, SAE	4
21	9.802-313.0	Engine, Robin, 6 HP, 200W (554.0)	1
	9.802-314.0	Engine, Robin, 7 HP, 200W (555.0)	1
	9.802-312.0	Engine, Honda, GX270QAR2, 9 HP, 18 AMP (550.0)	1
	9.802-320.0	Engine, Honda, GX340QNR2, 11 HP E/S, 18 AMP (552.0)	1
	9.802-319.0	Engine, Honda, GX340QAH2, 11 HP, 18 AMP (551.0)	1
	9.802-321.0	Engine, Honda, GX390KQNR2, 13 HP E/S, 18 Amp (553.0)	1
22	9.803-822.0	Pump, KG-2530G (554.0)	1
	9.803-823.0	Pump, KG-3030G (555.0)	1
	9.804.034.0	Pump, KG3035G1 (550.0)	1
	9.802-349.0	Pump, KS3540G (551.0, 552.0, 553.0)	1
23	9.802-242.0	Hose, 3/8" x 29" (551.0, 552.0, 553.0)	1
	9.802-241.0	Hose, 3/8" x 25", 2 Wire, Pressure Loop (550.0,554.0,555.0)	1
24	9.802-182.0	Pump Protector, 1/2" PTP	1
25	9.802-458.0	Switch, Pressure, N/O, 1/4" NPT SS (Except Steam Option)	1
26	9.802-039.0	Elbow, 1/2" JIC, 3/8", 90°	1
27	9.803-899.0	Unloader, VBA35 (555.0, 554.0, 550.0)	1
	9.803-900.0	Unloader, VBA35 6.6 @ 3500 (551.0, 552.0, 553.0)	1
28	9.802-148.0	Adapter, 1/2" x 1/2" Pipe	1
29	9.802-146.0	Swivel, 1/2" MP x 3/4" GHF w/Strainer	1
30	9.802-142.0	Hose Barb, 1/4" Barb x 1/8" ML Pipe, 90° (550.0, 551.0, 552.0, 553.0)	1
31	9.802-210.0	Clamp, Hose, UNI .46 - .54 (550.0, 551.0, 552.0, 553.0)	6
		(554.0, 555.0)	4

EXPLODED VIEWS PARTS LIST

ITEM	PART NO.	DESCRIPTION	QTY
32	9.802-254.0	Hose, 1/4", Push-On, Fuel Line (Steam Option)	14 in.
33	9.802-075.0	Box, Battery, M-100 (552.0, 553.0)	1
	9.802-076.0	▲ Plate, Battery Box, Large, PolyPro (552.0, 553.0)	1
34	9.802-081.0	Tank, Fuel, 6 Gallon	1
35	9.802-089.0	Cap, Fuel Tank, Plastic H60-AV	1
36	9.802-832.0	Bolt, 5/16" x 2-3/4" Whiz Loc (554.0, 555.0)	2
37	9.803-308.0	Mount, Rubber Vibration, 5/16", 70 Duro (554.0, 555.0)	4
	9.804-041.0	Mount, Rubber Vibration, 3/8", 70 Duro (550.0, 551.0, 552.0, 553.0)	4
38	9.802-064.0	Grommet, Rubber, Nozzle Holder	4
39	9.802-705.0	Bolt, 1/4" x 1" Carriage	4
40		Burner Assy, See Burner Spec's Page	
41	9.802-795.0	Nut, 5/16" Wing (552.0, 553.0)	4
42	9.802-781.0	Nut, 3/8" Flange, Whiz Loc	4
43	9.802-143.0	Hose Barb, 1/4" Barb x 1/4" Pipe, 90° (550.0, 551.0, 552.0, 553.0)	1
44	9.802-138.0	Hose Barb, 1/4" Barb x 1/4" ML Pipe	1
45	9.803-070.0	Axle, 30" (550.0, 551.0, 552.0, 553.0)	2
	9.803-110.0	Axle, 27.80" (554.0, 555.0)	2
46	9.800-008.0	Label, Danger Cool Engine	1
47	9.802-043.0	Elbow, 1/2" JIC x 1/2" Female, 90° (550.0, 551.0, 552.0, 553.0)	1
	9.802-042.0	Elbow, 1/2" JIC, 3/8", 90° (554.0, 555.0)	1
48	9.802-190.0	Valve, E-Z Start, 3/8" MPT x 1/8" FPT (550.0, 551.0, 552.0, 553.0)	1
49	9.802-792.0	Nut, Cage, 3/8" x 12 Gauge	4
50	9.802-531.0	Regulator, Voltage, 15 V (Pull Start)	1
	9.803-835.0	Regulator/Rectifier, 18 Amp (Electric Start)	1
51	9.802-709.0	Bolt, 5/16" x 3/4" NC	14
52	9.802-776.0	Nut, 5/16" ESNA (554.0, 555.0)	10
		(550.0, 551.0, 552.0, 553.0)	8
53	9.802-804.0	Washer, 5/16" Flat (554.0, 555.0)	28
		(550.0, 551.0, 552.0, 553.0)	18
54	9.802-755.0	Screw, 5/16" x 1-1/4", Whiz Loc (552.0, 553.0)	4
55	9.802-177.0	Valve, 1/4" Shut OFF	1
56	9.800-108.0	Label, Nozzle Identification (550.0, 551.0, 552.0, 553.0)	1
57	9.804-022.0	Cap, Valve w/1/4" Port (550.0, 554.0, 555.0)	1
	9.802-632.0	Cap, Valve w/1/4" Gauge Port (551.0, 552.0, 553.0)	1
58	9.802-901.0	Insulation, Tank Head	1
59	9.802-768.0	Screw, 3/8" x 1-1/4", Whiz Loc	4
60	9.802-793.0	Nut, Cage, 1/4" x 16 Gauge (550.0, 551.0, 552.0, 553.0)	5
		(554.0, 555.0)	4
61	9.800-021.0	Label, Hot Water Outlet	1
62	9.802-154.0	Plug, Push-On, Oil Drain, Honda (550.0, 551.0, 552.0, 553.0)	1
63	9.802-153.0	Swivel, 1/4" JIC FEM, Push-On	1
64	9.802-125.0	Plug, 1/4" JIC	1
65	9.803-836.0	Wire, THWN, 6 Gauge, Red (552.0, 553.0)	33"
66	9.803-837.0	Wire, THWN, 6 Gauge, Black (552.0, 553.0)	45"
67	9.803-838.0	Connector, Battery Post, Universal (552.0, 553.0)	2
68	9.802-778.0	Nut, 5/16" Flange, Whiz Loc (552.0, 553.0)	8

EXPLODED VIEW PARTS LIST

ITEM	PART NO.	DESCRIPTION	QTY
69	9.802-816.0	Washer, 7/16" Lock (551.0, 552.0, 553.0)	2
70	9.802-958.0	Key, 0.185 SQR x 1.75" (554.0, 555.0)	1
	9.802-959.0	Key, 0.247 SQR x 2.125 (550.0, 551.0, 552.0, 553.0)	1
71	9.802-754.0	Screw, 1/4" x 1/2" HH NC, Whiz Loc	4
72	9.802-773.0	Nut, 1/4"-20, ESNA	4
73	9.803-112.0	Bracket, Brake Pad, Black	1
74	9.800-094.0	Label, Warning, Text	1
75	9.800-002.0	Label, Use Only Kerosene	1
76	9.803-049.0	Bushing, 7/8" Snap (550.0, 551.0, 552.0, 553.0)	1
77	9.800-026.0	Label, Open For Steam (Steam Option)	1
78	9.802-010.0	Nipple, 1/4", Hex, Steel (Steam Option)	1
79	9.802-802.0	Washer, 1/4" Flat, SAE	12
80	9.802-187.0	Valve, Flow Control w/Metering (Steam Option)	1
81	9.802-120.0	Tee, 1/4" Branch Male, Legacy Pumps (Steam Option)	1
82	9.803-043.0	Nipple, 1/4" x 2", Galvanized	1
83	9.802-997.0	Linkage, Brake, Black	1
84	9.802-212.0	Filter, Parker Fuel/Oil/H ₂ O (10 Micron), Generic	1
85	9.802-254.0	Hose, 1/4" Push On	9"
86	9.802-254.0	Hose, 1/4" Push On (550.0, 551.0, 552.0, 553.0) (554.0, 555.0)	7" 11"
87	9.802-428.0	Service Cord, 12/3 SJOWA (550.0, 551.0, 552.0, 553.0) (554.0, 555.0)	40" 32"
88	9.802-519.0	Strain Relief, 1/2"	1
89	9.802-713.0	Bolt, 5/16" x 1-1/2" (554.0, 555.0)	2
	9.802-723.0	Bolt, 3/8" x 1-3/4", NC H ((550.0, 551.0, 552.0, 553.0)	4
90	9.802-813.0	Lock Washer, 5/16"	2
	9.802-814.0	Washer, 3/8", Lock Split Ring ((550.0, 551.0, 552.0, 553.0)	4
91	9.802-813.0	Lock Washer, 5/16" (552.0, 553.0)	4
92	9.802-013.0	Nipple, Galvanized, 1/2" x 2-1/2" (550.0, 551.0, 552.0, 553.0)	1
93	9.802-254.0	Hose, 1/4" Push On	14"
94	9.802-707.0	Bolt, 5/16" - 24 x 3/4" NF (554.0, 555.0)	4
	9.802-768.0	Screw, 3/8" x 1-1/4" Whiz Loc (550.0, 551.0, 552.0, 553.0)	4
95	9.802-143.0	Elbow, 1/4" Hose Barb x 1/4" Pipe, Steam Option (550.0, 551.0, 552.0, 553.0)	1
96	9.803-052.0	Reducer, M14 x 1/4" F (554.0, 555.0)	1
97	9.802-138.0	Hose Barb, 1/4" x Barb x 1/4" (554.0, 555.0)	1
98	9.802-143.0	Hose Barb, 1/4" Barb x 1/4" Pipe, 90°	1
99	9.803-839.0	Elbow, 1/4" Street	1
100	9.802-103.0	Bushing, 5/8" Snap (554.0, 555.0)	1
101	9.802-908.0	Insulation, Blanket, 18" x 52", Fiberglass (554.0, 555.0)	1
102	9.803-111.0	Lever, Brake, Black	1
103	9.802-771.0	Screw, 10/32" x 3/4" BH SOC CS (550.0, 551.0, 554.0, 555.0)	3
	9.802-762.0	Screw, 10/32" x 1-1/4" RH SL (552.0, 553.0)	2
104	9.802-695.0	Nut, 10/32" Kep (552.0, 553.0) (550.0, 551.0, 554.0, 555.0)	2 3
105	9.802-140.0	Hose Barb, 1/4" Barb x 3/8", Double	1
106	9.802-053.0	Bushing, Rubber Nitrile	2
107	9.802-813.0	Washer, 5/16" Lock Split Ring (554.0, 555.0)	4

EXPLODED VIEW PARTS LIST

ITEM	PART NO.	DESCRIPTION	QTY
108	9.802-512.0	Cable, Tie, 48"	2
109	9.802-459.0	Switch, MV60 Flow (Steam Option)	1
110	9.802-104.0	Bushing, 3/4" Snap (554.0, 555.0)	1
111	9.802-254.0	Hose, 1/4" Push-On (554.0, 555.0) (550.0, 551.0, 552.0, 553.0)	7" 11"
112	9.802-039.0	Elbow, 1/2" JIC x 3/8", 90° (Steam Option)	1
113	9.802-143.0	Elbow, 1/4" x 1/4" Pipe (Steam Option)	2
114	9.802-047.0	Adapter, 1/2" x 1/2" Pipe STL	1
115	9.802-045.0	Bushing, 1/2" x 3/8" STL	1
116	9.802-041.0	Elbow, 3/8" STL, Street, 45°	1
117	9.800-011.0	Label, RPM Factory Set	1
118	9.802-011.0	Nipple, 3/4" Hex (554.0, 555.0)	1
119	9.802-811.0	Washer, Fender (554.0, 555.0)	2
120	9.800-018.0	Label, Tipover Hazard	1
121	9.800-049.0	Label, Cleaning Solution	1
122	9.802-112.0	Elbow, 3/8" Female	1
123	9.802-807.0	Washer 3/8", SAE Flat (550.0, 551.0, 552.0, 553.0)	4
124	9.802-744.0	Bolt, 10 mm x 20 mm (551.0, 552.0, 553.0)	2
	9.802-741.0	Bolt, 8 mm x 16 mm HEX Head (550.0)	2
125	9.802-066.0	Pad, Soft Rubber	1
126	9.802-722.0	Bolt, 3/8" x 1-1/4", NC HH	1
127	9.802-817.0	Washer, 3/8" x 1", Steel	1
128	9.802-779.0	Nut, 3/8" ESNA	1
129	9.804-038.0	Rail, Pump Support (551.0, 552.0, 553.0)	1
	9.804-533.0	Rail, Pump Support (550.0)	1
130	9.803-026.0	Tab, Outer Wrap (550.0, 551.0, 552.0, 553.0)	4
131	9.802-794.0	Nut Cage, 1/4" x 12 Gauge (550.0, 551.0, 552.0, 553.0)	8
132	9.802-124.0	Plug, 1/4" Countersunk	1

▲ Not Shown

CONTROL PANEL EXPLODED VIEW - 554.0, 555.0 MODELS

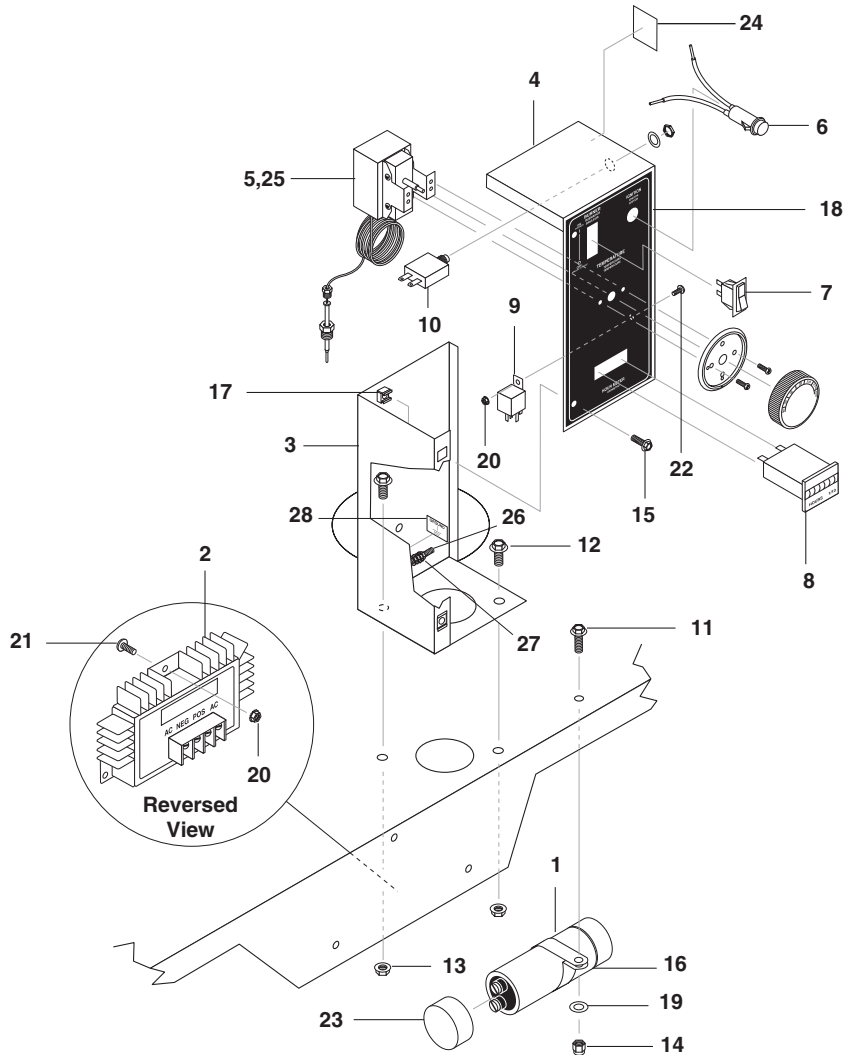

554.0, 555.0 CONTROL PANEL PARTS LIST

ITEM	PART NO.	DESCRIPTION	QTY
1	9.802-528.0	Capacitor	1
2	9.802-531.0	Regulator, Voltage, 15 Volt	1
3	9.803-036.0	Box, Electrical	1
4	9.803-121.0	Assembly, Cover, Electrical Box	1
5	9.802-285.0	Thermostat, Adjustable, 302°F	1
6	9.802-456.0	Light, Indicator, Green 12 Volt	1
7	9.802-453.0	Switch, Curvette RA901VB-B-1-V, Carling	1
8	9.802-284.0	Meter, Hobbs Hour	1
9	9.802-470.0	Relay, P & B, VF4-41F11, 12VDC, 40AMP	1
10	9.802-485.0	Breaker, 1658-G41-02-P10-25A	1
11	9.802-752.0	Screw, 1/4" x 1-1/4" Hex, Whiz Loc	1
12	9.802-754.0	Screw, 1/4" x 1/2" HH NC, Whiz Loc	2
13	9.802-775.0	Nut, 1/4" Whiz Loc	2
14	9.802-773.0	Nut, 1/4", ESNA, NC	1
15	9.802-764.0	Screw, 10/32" x 3/4" Hex	2

554.0, 555.0 CONTROL PANEL PARTS LIST

ITEM	PART NO.	DESCRIPTION	QTY
16	9.802-206.0	Clamp, Hose	1
17	9.802-791.0	Nut, Cage, 10/32" x 16 Gauge	2
18	9.800-098.0	Label, Control Panel	1
19	9.802-802.0	Washer, 1/4", Flat, SAE	1
20	9.802-695.0	Nut, 10/32" Keps	4
21	9.802-771.0	Screw, 10/32" x 3/4"	3
22	9.802-759.0	Screw, 10/32" x 1/2"	1
23	9.803-048.0	Cap, Capacitor, 1.37 x 1.50 x .060 Blk, w/o Hole	1
24	9.803-840.0	Label, Reset	1
25	9.802-447.0	▲ Conduit, 1/4" Split	36"
26	9.802-762.0	Screw, 10/32" x 1-1/4" (Ground)	1
27	9.802-695.0	Nut, 10/32", Keps	4
28	9.800-040.0	Ground Label	1

▲ Not Shown

CONTROL PANEL - 550.0, 551.0, 552.0, 553.0

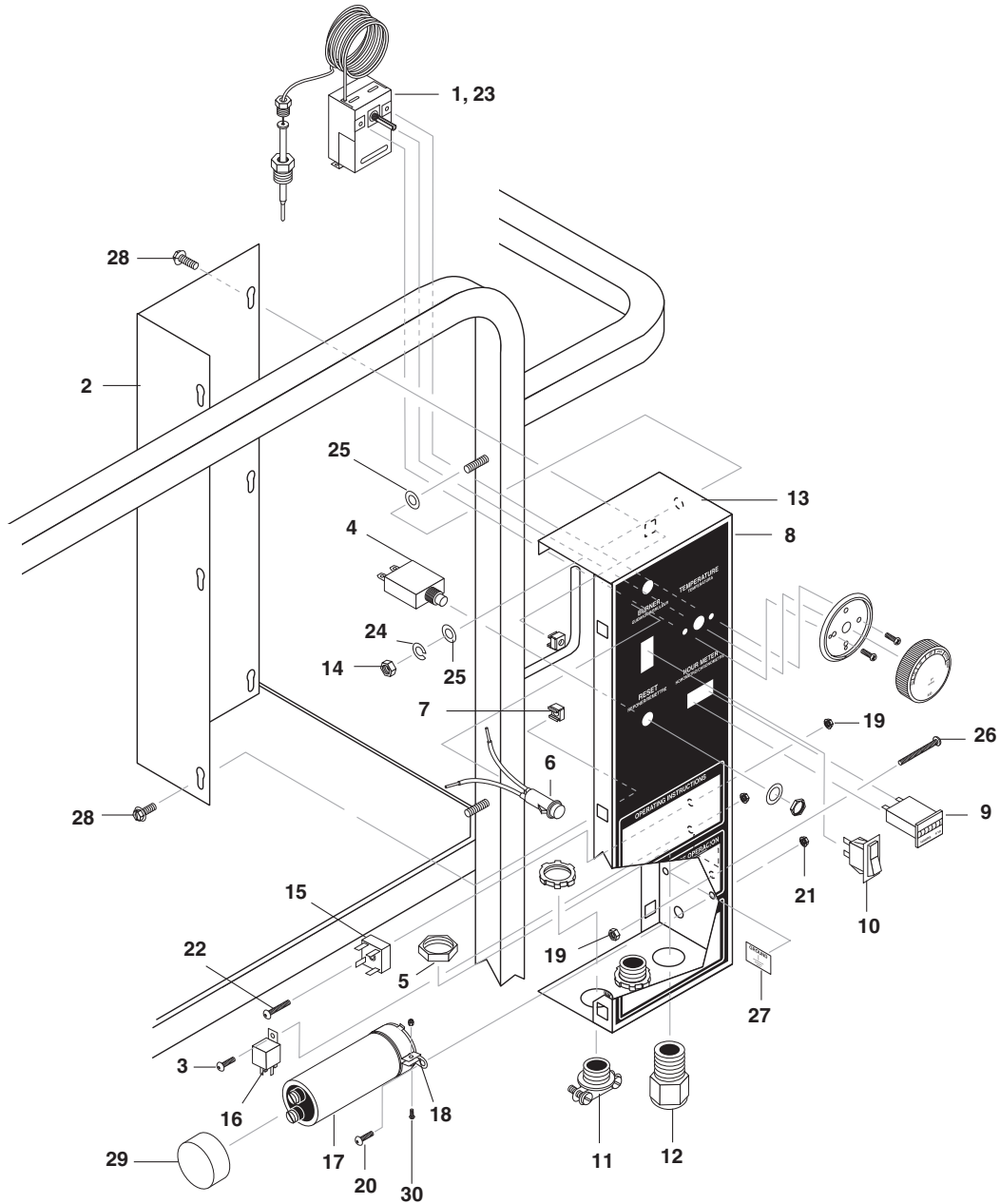

550.0, 551.0, 552.0, 553.0 CONTROL PANEL PARTS LIST

ITEM	PART NO.	DESCRIPTION	QTY
1	9.802-285.0	Thermostat, Adjustable, 302°F	1
2	9.803-035.0	Cover, Electric Box, Black	1
3	9.802-759.0	Screw, 10/32" x 1/2" BHSOC, Black	1
4	9.802-485.0	Breaker, 1658-G41-02-P10-25A	1
5	9.802-525.0	Locknut, 1/2"	1
6	9.802-456.0	Light, Indicator, Green 12V	1
7	9.802-791.0	Cage, Nut, 10/32" x 16 Gauge	6
8	9.800-113.0	Label, Control Panel	1
9	9.802-284.0	Hour Meter, Hobbs, 12-48VDC	1

550.0, 551.0, 552.0, 553.0 CONTROL PANEL PARTS LIST

ITEM	PART NO.	DESCRIPTION	QTY
10	9.802-453.0	Switch, Curvette RA901VB-B-1-V, Carling	1
11	9.802-519.0	Strain Relief, 1/2" Metal, Two Screw	2
12	9.802-514.0	Strain Relief, Small	1
13	9.803-071.0	Box, Electric, Black	1
14	9.802-786.0	Nut, 5/16" Hex	2
15	9.802-530.0	Rectifier, Bridge (552.0, 553.0)	1
16	9.802-470.0	Relay, P & B, VF4-41F11, 12VDC, 40AMP	1
17	9.802-528.0	Capacitor (550.0, 551.0)	1
18	9.802-529.0	Bracket, Capacitor (550.0, 551.0)	1
19	9.802-695.0	Nut, 10/32" Keps	8
20	9.802-748.0	Screw, 6/32" x 3/8", RND HD MCH (550.0551.0)	2
21	9.802-784.0	Nut, 6/32" Keps (550.0, 551.0)	3
22	9.802-771.0	Screw, 10/32" x 3/4" BH SOC CS (552.0, 553.0)	1
23	9.802-447.0	▲ Conduit, Split, 1/4"	66"
24	9.802-813.0	Washer, 5/16", Lock, Split Ring	2
25	9.802-806.0	Washer, 5/16", Flat, Cut	4
26	9.802-762.0	Screw, 10/32" x 1-1/4" (Ground)	1
27	9.800-040.0	Label, Ground	1
28	9.802-764.0	Screw, 10/32" x 3/4", HEX	6
29	9.803-048.0	Cap, Capacitor, 1.37 x 1.5 x .06 Blk, w/o Hole (551.0, 555.0)	1
30	9.802-747.0	Screw, 6/32" x 5/8" (550.0, 551.0)	1

▲ Not Shown

HOSE & SPRAY GUN ASSEMBLY

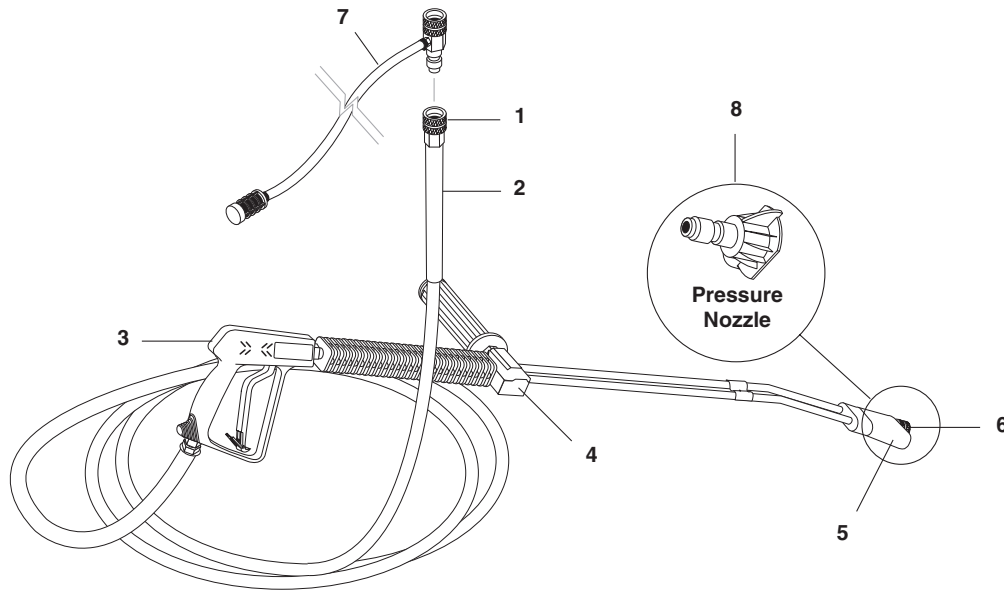

HOSE & SPRAY GUN PARTS LIST

ITEM	PART NO.	DESCRIPTION	QTY
1	9.802-166.0	Coupler, 3/8" Female	1
	9.802-100.0	▲ Quick Coupler O-Ring LG	1
2	9.802-249.0	Hose, 3/8" x 50', 1 Wire, w/Coupler (All Models Except 553.0)	1
	9.802-250.0	Hose Only, 3/8" x 50', 2 Wire, Red w/Coupler (553.0)	1
3	9.802-229.0	Spray Gun, Shutoff, AP 1000	1
4	9.802-222.0	Wand, VP Zinc 1/4", w/Coupler, w/Soap Nozzle	1
	9.802-694.0	▲ Repair Kit, VP Wand, SS Seat	1
5	9.802-286.0	Nozzle, 1/8", Soap Only, Brass	1
6	9.802-165.0	Coupler, 1/4" Male	1
	9.802-096.0	▲ Quick Coupler, O-Ring, Small	1
7	9.802-225.0	Detergent Injector Assy. #3 (550.0, 551.0, 552.0, 553.0)	1
	9.802-224.0	Detergent Injector Assy. #2 (554.0, 555.0)	1
8	9.802-292.0	Nozzle, SAQMEG 1503.5, Yellow (553.0, 554.0, 555.0)	1
	9.802-293.0	Nozzle, SAQMEG 2503.5, Green (553.0, 554.0, 555.0)	1
	9.802-294.0	Nozzle, SAQMEG 4003.5, White (553.0, 554.0, 555.0)	1
	9.802-291.0	Nozzle, SAQMEG 0003.5, Red (553.0, 554.0, 555.0)	1
	9.802-296.0	Nozzle, SAQMEG 1504, Yellow (551.0, 552.0)	1
	9.802-297.0	Nozzle, SAQMEG 2504, Green (551.0, 552.0)	1
	9.802-298.0	Nozzle, SAQMEG 4004, White (551.0, 552.0)	1
	9.802-295.0	Nozzle, SAQMEG 0004, Red (551.0, 552.0)	1
	9.802-288.0	Nozzle, SAQMEG 1503, Yellow (550.0)	1
	9.802-289.0	Nozzle SAQMEG 2503, Green (550.0)	1
	9.802-290.0	Nozzle SAQMEG 4003, White (550.0)	1
	9.802-287.0	Nozzle SAQMEG 0003, Red (550.0)	1

▲ Not Shown

DOWNSTREAM INJECTOR ASSEMBLY

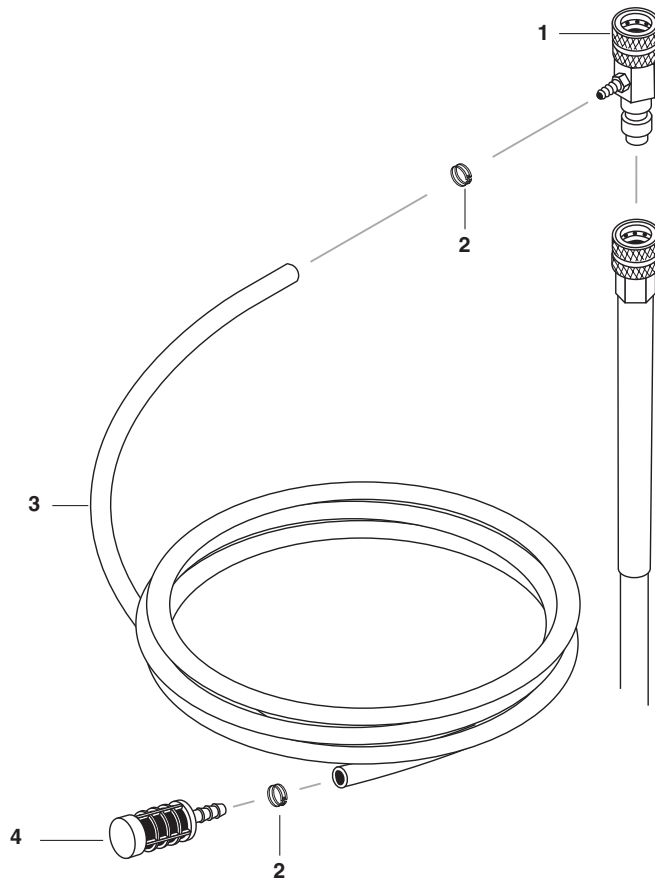

DOWNSTREAM INJECTOR PARTS LIST

ITEM	PART NO.	DESCRIPTION	QTY
1	9.802-216.0	Injector, Detergent, Non-Adjusting #3	1
	9.802-215.0	Injector, Detergent, Non-Adjusting #2	1
2	9.802-210.0	Clamp, Hose, UNI .46 - .54	2
3	9.802-251.0	Tube, 1/4" x 1/2", Clear Vinyl	6 ft.
4	9.802-160.0	Strainer, 1/4", Hose Barb	1

HOSE REEL OPTION

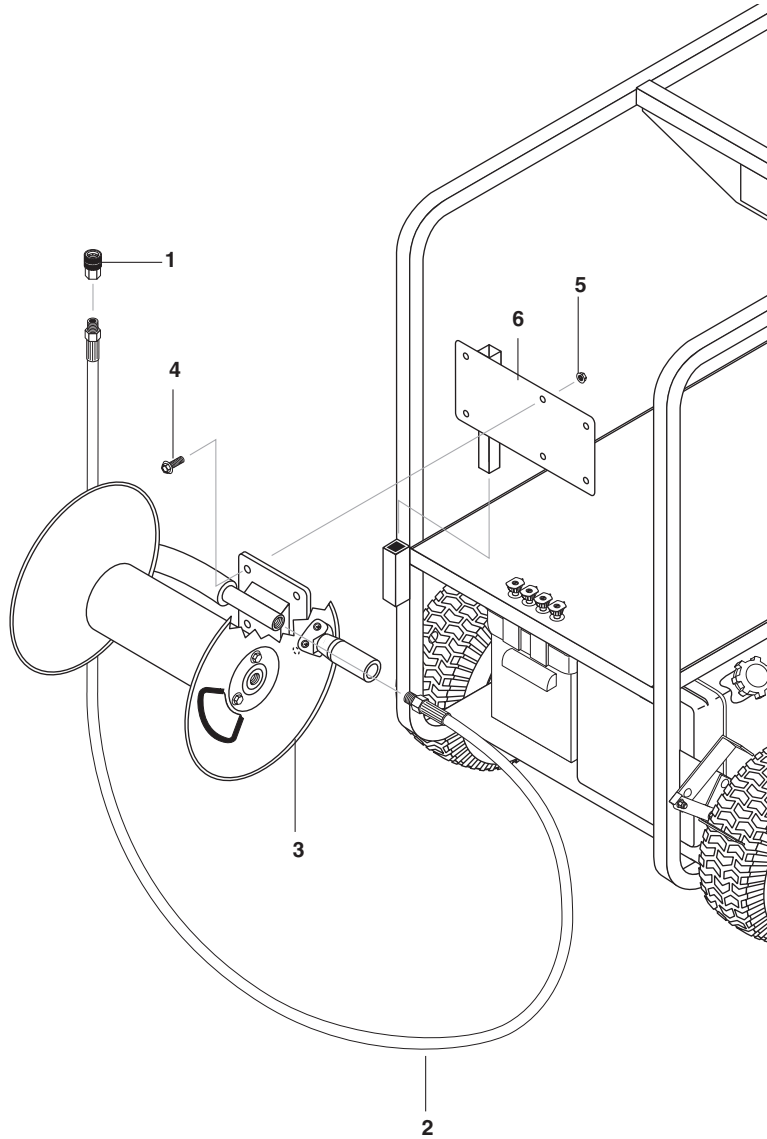

HOSE REEL PARTS LIST

ITEM	PART NO.	DESCRIPTION	QTY
1	9.802-166.0	Coupler, 3/8", Female, Brass	1
2	9.802-244.0	Hose, 3/8", 2 Wire Pressure Loop	1
3	9.802-269.0	Hose Reel, 100' Non-Pivot E-ZEE w/Pin Lock	1
4	9.802-767.0	Screw, 3/8" x 3/4" HH NC, Whiz Loc	4
5	9.802-781.0	Nut, 3/8" Flange, Whiz Loc, NC	4
6	9.803-841.0	Bracket, E-ZEE Hose Reel Right, Wrinkle Black	1

VBA35 UNLOADER EXPLODED VIEW

9.803-899.0 KD 25 LPM @ 240 BAR
 9.803-900.0 KM 25 LPM @ 240 BAR

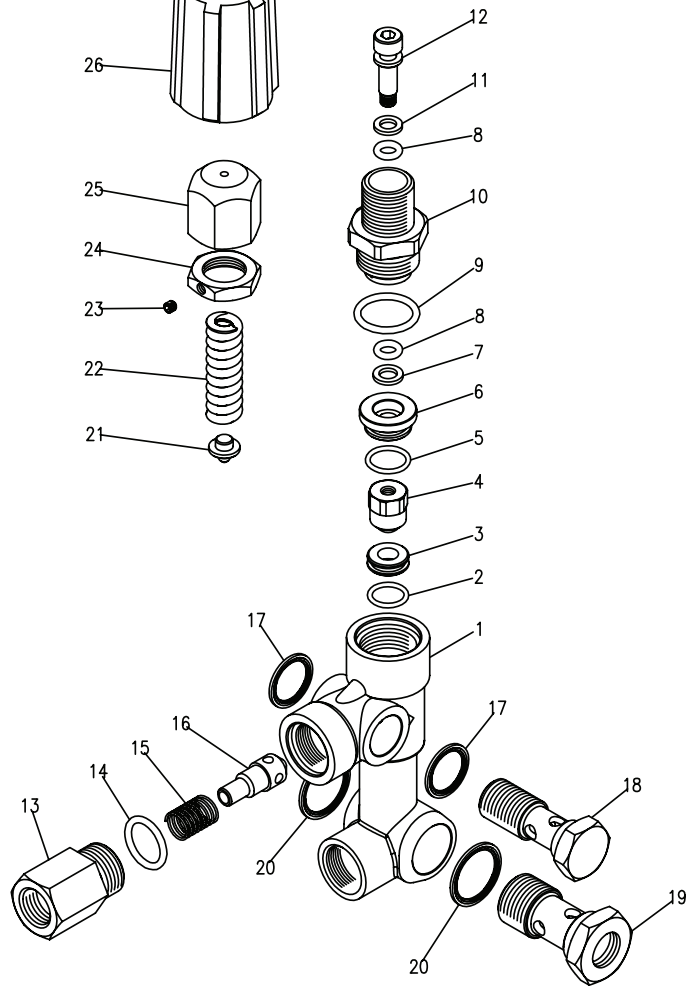

VBA35 UNLOADER EXPLODED VIEW PARTS LIST

ITEM	PART #	DESCRIPTION	KIT	QTY	ITEM	PART #	DESCRIPTION	KIT	QTY
1	9.803-901.0	Body Valve (KM)		1	15	9.803-916.0	Spring	B	1
	9.803-902.0	Body Valve (KD)		1	16	9.803-917.0	Poppet	B	1
2	9.803-903.0	O-Ring	A, C	1	17	9.802-893.0	Seal Washer 3/8		2
3	9.803-904.0	Seat	C	1	18	9.803-920.0	Banjo Bolt, 3/8 w/ 1/8 Pilot		1
4	9.803-905.0	Ball, Sub-assy	C	1	19	9.803-915.0	Banjo Bolt 1/2		1
5	9.803-906.0	O-Ring	A	1	20	9.803-921.0	Seal Washer 1/2		2
6	9.803-907.0	Guide Bushing		1	21	9.803-922.0	Plate	C	1
7	9.803-908.0	Teflon Ring	A	1	22	9.803-923.0	Spring	C	1
8	9.803-909.0	O-Ring	A	2	23	9.803-924.0	Set Screw		1
9	9.803-910.0	O-Ring	A	1	24	9.803-925.0	Nut		1
10	9.803-911.0	Connector		1	25	9.803-926.0	Brass Handle		1
11	9.803-912.0	Teflon Ring	A	1	Kit A	9.803-927.0	O-Ring Repair Kit		
12	9.803-913.0	Stem	C	1	Kit B	9.803-928.0	Outlet Kit		
13	9.803-914.0	Connector, Female		1	Kit C	9.803-929.0	Stem Repair Kit		
14	9.803-191.0	O-Ring	A, B	1					

KG PUMP EXPLODED VIEW

9.803-822.0 KG2530G

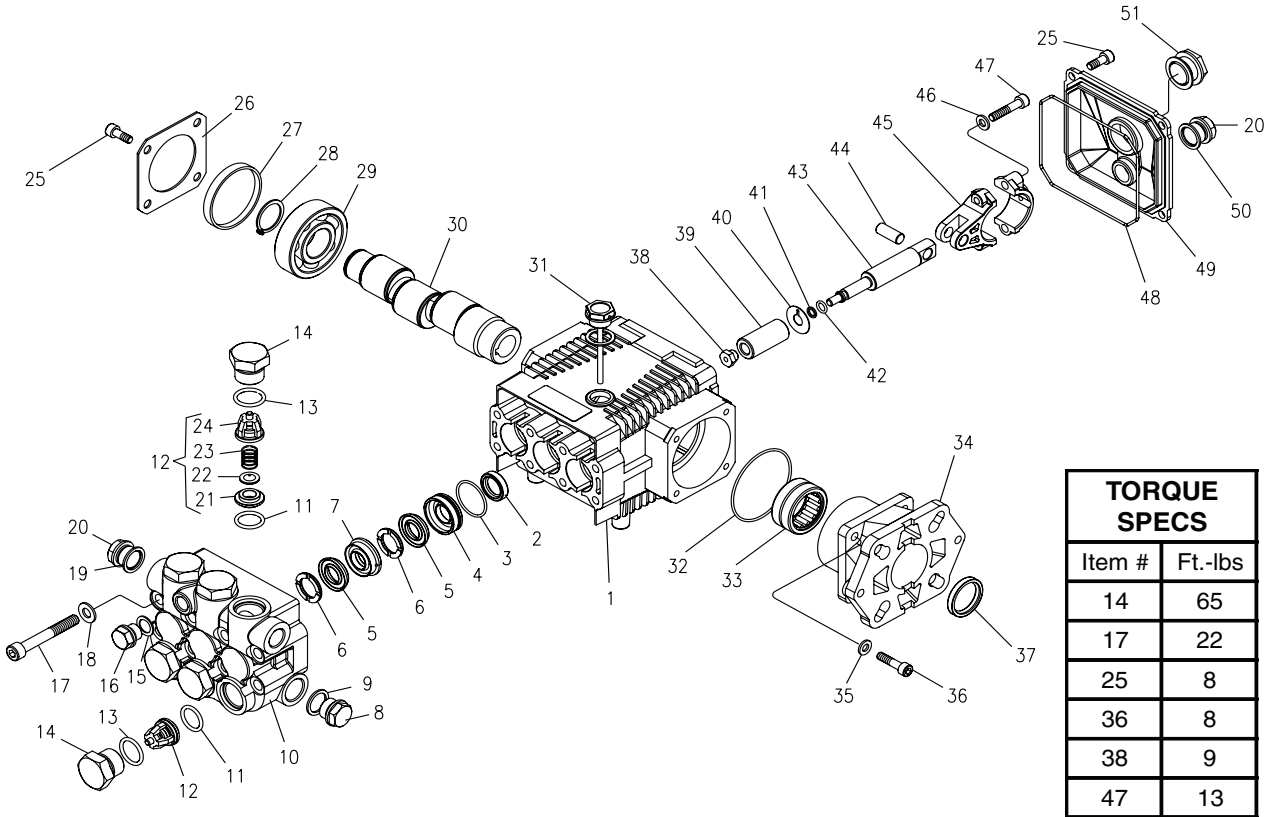

KG PUMP EXPLODED VIEW PARTS LIST

ITEM	PART NO.	DESCRIPTION	QTY	ITEM	PART NO.	DESCRIPTION	QTY
1	70-020292	Crankcase	1	18	70-140001	Washer	8
2*	See Kit Below	Plunger Oil Seal	3	19	70-060306	Copper Washer 3/8"	1
3*	70-060181	O-Ring Ø1.78 x 28.30	3	20	70-160117	Brass Plug 3/8"	2
4*	70-120120	Pressure Ring, 15mm	3	25	70-180112	Hexagonal Screw	9
5*	See Kit Below	"V" Seal, 15mm	6	26	70-020318	Bearing Cover	1
6*	70-030048	Support Ring 15mm	6	27	70-020502	Seal Bearing	1
7*	70-030049	Intermediate Ring 15mm	3	28	70-150003	Snap Ring	1
8	70-160120	Brass Plug, 1/2"	1	29	70-021300	Ball Bearing	1
9	70-060307	Copper Washer 1/2"	1	30	70-000498	Crankshaft (2530G)	1
10	70-160228	Manifold Housing	1		70-000499	Crankshaft (3030G)	1
11*	70-060155	O-Ring Ø1.78 x 15.54	6	31	70-160012	Oil Dip Stick	1
12*	See Kit Below	Valve Assembly	6	32	70-060183	O-Ring 3.53 x 55.56	1
13*	70-060122	O-Ring Ø2.62 x 18.77	6	33	70-020011	Needle Roller Bearing	1
14	70-160147	Valve Plug	6	34	70-050096	Engine Flange	1
15	70-060308	Washer, Copper	1	35	70-140002	Spring Washer	4
16	70-160121	Brass Plug G1/4	1	36	70-180126	Flange Screw	4
17	70-180118	Manifold Stud Bolt	8				

KG PUMP EXPLODED VIEW PARTS LIST (CONT)

ITEM	PART NO.	DESCRIPTION	QTY
37	70-000105	Crankshaft Seal	1
38*	70-030211	Plunger Nut	3
39*	See Kit Below	Plunger, 15mm	3
40*	70-140027	Copper Spacer	3
41*	70-060130	O-Ring Ø1.78x5.28	3
42*	70-000913	Teflon Ring	3
43	70-000320	Plunger Rod	3
44	70-150204	Connecting Rod Pin	3
45	70-010008	Connecting Rod	3
46	70-140102	Spring Washer	6
47	70-180132	Connecting Rod Screw	6
48	70-060104	O-Ring 2.62 x 107.62	1
49	70-020352	Crankcase Cover	1
50	70-060302	Gasket, G3/8	1
51	70-070005	Sightglass G3/8	1

* Part available in kit (See below)

REPAIR KIT NUMBER	70-261408	70-261409	70-261404	70-260028	70-260826
KIT DESCRIPTION	Plunger Seal 15mm	Complete Seal Packing 15mm	Plunger 15mm	Complete Valve	Plunger Oil Seals
ITEM NUMBERS INCLUDED	3, 5, 6	2, 3, 4, 5, 6, 7	38, 39, 40, 41, 42	11, 12, 13	2
NUMBER OF CYLINDERS KIT WILL SERVICE	3	1	1	6	3

KG-1 PUMP EXPLODED VIEW

9.803-819.0 KG3035G1
 9.803-820.0 KG3535G1
 9.803-821.0 KG4030G1

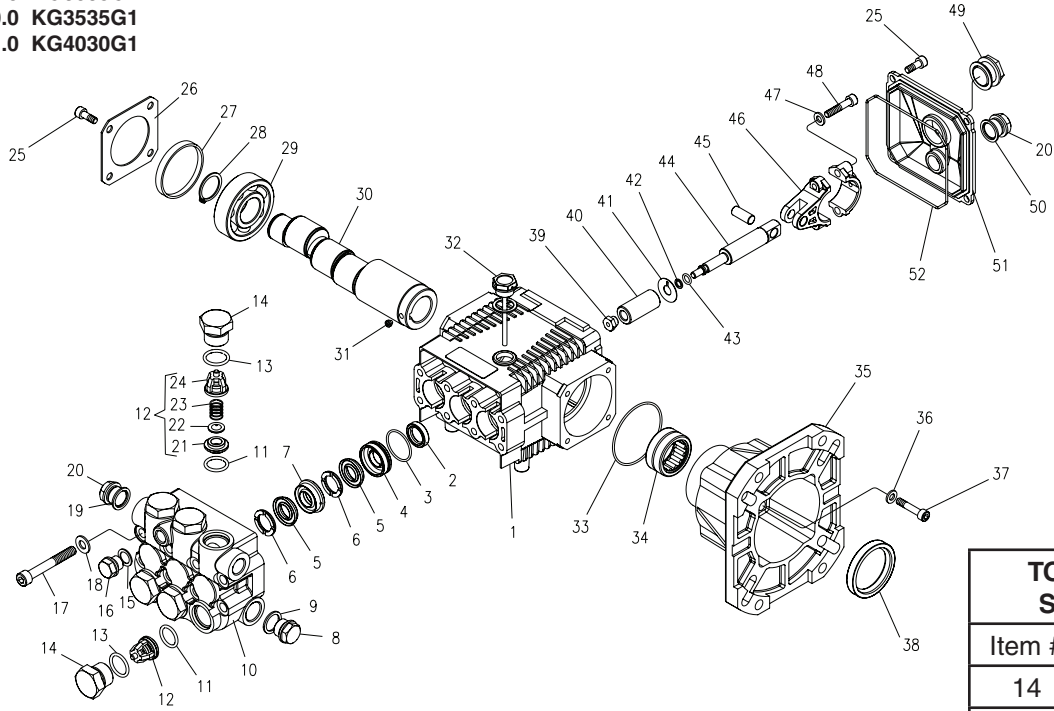

TORQUE SPECS	
Item #	Ft.-lbs
14	65
17	22
25	8
37	8
39	9
48	13

KG-1 PUMP EXPLODED VIEW PARTS LIST

ITEM	PART NO.	DESCRIPTION	QTY	ITEM	PART NO.	DESCRIPTION	QTY
1	70-020292	Crankcase	1	19	70-060306	Copper Washer 3/8"	1
2*	See Kit Below	Plunger Oil Seal	3	20	70-160117	Brass Plug 3/8"	2
3*	70-060107	O-Ring Ø1.78 x 31.47	3	25	70-180112	Hexagonal Screw	9
4*	70-120120	Pressure Ring, 15mm	3	26	70-020318	Bearing Cover	1
5*	See Kit Below	"V" Seal, 15mm	6	27	70-020502	Seal Bearing	1
6*	70-030027	Support Ring 15mm	6	28	70-150003	Snap Ring	1
7	70-030049	Intermediate Ring 15mm	3	29	70-021300	Ball Bearing	1
8	70-160120	Brass Plug, 1/2"	1	30	70-000495	Crankshaft (3035G1)	1
9	70-060307	Copper Washer 1/2"	1		70-000496	Crankshaft (3535G1)	1
10	70-160228	Manifold Housing	1		70-000497	Crankshaft (4030G1)	1
11*	70-060155	O-Ring Ø1.78 x 15.54	6	31	70-180302	Set Screw	1
12*	See Kit Below	Valve Assembly	6	32	70-160012	Oil Dip Stick	1
13*	70-060122	O-Ring Ø2.62 x 18.77	6	33	70-060183	O-Ring 3.53 x 55.56	1
14	70-160147	Valve Plug	6	34	70-020010	Needle Roller Bearing	1
15	70-060308	Washer, Copper	1	35	70-050055	Engine Flange	1
16	70-160121	Brass Plug G1/4	1	36	70-140002	Spring Washer	4
17	70-180118	Manifold Stud Bolt	8	37	70-180132	Flange Screw	4
18	70-140001	Washer	8				

KG-1 PUMP EXPLODED VIEW PARTS LIST (CONT)

ITEM	PART NO.	DESCRIPTION	QTY
38	70-000109	Crankshaft Seal	1
39*	70-030211	Plunger Nut	3
40*	See Kit Below	Plunger, 15mm	3
41*	70-140027	Copper Spacer	3
42*	70-060130	O-Ring Ø1.78x5.28	3
43*	70-000913	Teflon Ring	3
44	70-000320	Plunger Rod	3
45	70-150204	Connecting Rod Pin	3
46	70-010008	Connecting Rod	3
47	70-140102	Spring Washer	6
48	70-180132	Connecting Rod Screw	6
49	70-070005	Sight Glass, G3/8	1
50	70-060302	Gasket, G3/8	1
51	70-020352	Crankcase Cover	1
52	70-060104	O-Ring 2.62 x 107.62	1

* Part available in kit (See below)

REPAIR KIT NUMBER	70-261408	70-261409	70-261404	70-260028	70-260826
KIT DESCRIPTION	Plunger Seal 15mm	Complete Seal Packing 15mm	Plunger 15mm	Complete Valve	Plunger Oil Seals
ITEM NUMBERS INCLUDED	3, 5, 6	2, 3, 4, 5, 6, 7	39, 40, 41, 42, 43	11, 12, 13	2
NUMBER OF CYLINDERS KIT WILL SERVICE	3	1	1	6	3

SPECIFICATIONS

BECKETT BURNER SPECIFICATIONS

Model #	Burner Assy #	Fuel Nozzle	Transformer	Burner Motor	Fuel Pump/ Solenoid Cord	Fuel Pump/ Solenoid Coil	Electrode
1.575-554.0	9.802-554.0	9.802-585.0	9.802-663.0	9.802-638.0	9.802-562.0	9.802-639.0	9.802-670.0
1.575-555.0	9.802-554.0	9.802-585.0	9.802-663.0	9.802-638.0	9.802-562.0	9.802-639.0	9.802-670.0
1.575-550.0	9.802-560.0	9.802-582.0	9.802-663.0	9.802-638.0	9.802-562.0	9.802-639.0	9.802-670.0
1.575-551.0	9.802-560.0	9.802-575.0	9.802-663.0	9.802-638.0	9.802-562.0	9.802-639.0	9.802-670.0
1.575-552.0	9.802-560.0	9.802-575.0	9.802-663.0	9.802-638.0	9.802-562.0	9.802-639.0	9.802-670.0
1.575-553.0	9.802-560.0	9.802-576.0	9.802-663.0	9.802-639.0	9.802-562.0	9.802-639.0	9.802-670.0

**LIMITED NEW PRODUCT
WARRANTY—COMMERCIAL
PRESSURE WASHERS**



Phone: 888-805-9852
Fax: 800-248-8409
www.karchercommercial.us

PRESSURE WASHER WARRANTY

WHAT THIS WARRANTY COVERS

All Kärcher commercial pressure washers are warranted by Kärcher to the original purchaser to be free from defects in materials and workmanship under normal use, for the periods specified below. This Limited Warranty, subject to the exclusions shown below, is calculated from the date of the original purchase, and applies to the original components only. Any parts replaced under this warranty will assume the remainder of the pressure washer's warranty period.

FIVE YEAR PARTS AND ONE YEAR LABOR WARRANTY

Components manufactured by Kärcher, such as frames, handles, float tanks, fuel tanks, belt guards, and heating coils. Internal components on the oil-end of Kärcher pumps have a 5 year warranty. Heating coils are pro-rated at 25% after 2 years. Stainless steel coils have a 10 year warranty.

ONE YEAR PARTS AND ONE YEAR LABOR WARRANTY

All other components, excluding normal wear items as described below, will be warranted for one year on parts and labor. Parts and labor warranty on these parts will be for one year regardless of the duration of the original component manufacturer's part warranty.

WARRANTY PROVIDED BY OTHER MANUFACTURERS

Motors, generators, and engines, which are warranted by their respective manufacturers, are serviced through these manufacturers' local authorized service centers. Kärcher is not authorized and has no responsibility to provide warranty service for such components. Motors manufactured outside of the United States will be warranted by Kärcher.

WHAT THIS WARRANTY DOES NOT COVER

This warranty does not cover the following items:

1. Normal wear items, such as nozzles, spray guns, discharge hoses, wands, quick couplers, seals, filters, gaskets, O-rings, packings, pistons, pump valve assemblies, strainers, belts, brushes, rupture disks, fuses, pump protectors.
2. Any components or other devices incorporated into a Kärcher product that are not manufactured by Kärcher, including, but not limited to gasoline engines, pumps, etc.
3. Defects caused by improper or negligent operation or installation, accident, abuse, misuse, neglect, unauthorized modifications, repair or maintenance of the product by persons other than authorized representatives of Kärcher, including, but not limited to, the failure of the Customer to comply with recommended product maintenance schedules.
4. Kärcher products that have been returned by the original Customer and are ultimately re-sold by an Authorized Servicing Dealer or other sales or service outlet to another purchaser.
5. Kärcher products that are sold by any distributor or retailer that is not an official authorized dealer or retailer of Kärcher products.
6. Defects caused by acts of nature and disaster including, but not limited to, floods, fires, wind, freezing, earthquakes, tornados, hurricanes and lightning strikes.
7. Defects caused by water sediments, rust corrosion, thermal expansion, scale deposits or a contaminated water supply (such as water in the unit with chloride content higher than that of 80 mg/liter or use of chemicals not approved or recommended by Kärcher).
8. Defects caused by improper voltage, voltage spikes or power transients in the electrical supply.
9. Devices or accessories not distributed or approved by Kärcher.
10. Any cost of labor arising from the removal and reinstallation of the alleged defective part by Customer.
11. Transportation of the product to an Authorized Servicing Dealer, field labor, replacement rental and any freight charges.

Any components, accessories or other devices provided with the product but not manufactured by Kärcher (such as engines, pumps, etc.) are subject to warranties and service through their respective manufacturers authorized service centers and according to the applicable terms and conditions of such manufacturers warranties. Such components or other devices not manufactured by Kärcher should be referred by the Customer to an authorized service center or their respective manufacturers for repair or replacement.

THE FOREGOING WARRANTY IS IN LIEU OF ALL OTHER WARRANTIES OF ANY KIND, WHETHER ARISING BY LAW, CUSTOM OR CONDUCT. KÄRCHER MAKES NO ADDITIONAL WARRANTIES, EITHER EXPRESSED OR IMPLIED, INCLUDING, WITHOUT LIMITATION, ANY EXPRESSED OR IMPLIED WARRANTIES OF MERCHANTABILITY OR FITNESS OF EQUIPMENT FOR A PARTICULAR PURPOSE AND ANY SUCH WARRANTIES ARE EXPRESSLY DISCLAIMED. KÄRCHER FURTHER DISCLAIMS ANY WARRANTY THAT THE PRODUCT PURCHASED BY CUSTOMER WILL MEET ANY PARTICULAR REQUIREMENT OF CUSTOMER EVEN IF KÄRCHER HAS BEEN ADVISED OF SUCH REQUIREMENT.

THE RIGHTS AND REMEDIES PROVIDED UNDER THIS WARRANTY ARE EXCLUSIVE AND IN LIEU OF ANY OTHER RIGHTS OR REMEDIES OF CUSTOMER. KÄRCHER SHALL NOT UNDER ANY CIRCUMSTANCES BE LIABLE TO ANY PERSON OR ENTITY INCLUDING, BUT NOT LIMITED TO, THE CUSTOMER OR ANY END USER OF THE PRODUCT FOR ANY SPECIAL, INDIRECT, INCIDENTAL OR CONSEQUENTIAL DAMAGES OR ECONOMIC LOSS, LOSS OF PROFITS OR LOSS OF USE OF THE PRODUCT, ARISING IN CONNECTION WITH THE SALE, DELIVERY, INSTALLATION, TRAINING OR USE OF PRODUCT.

KÄRCHER'S LIABILITY, WHETHER IN CONTRACT OR IN TORT, ARISING OUT OF ANY WARRANTIES OR REPRESENTATIONS, INSTRUCTIONS OR DEFECTS FROM ANY CAUSE, SHALL BE LIMITED EXCLUSIVELY TO THE COST OF REPAIR OR REPLACEMENT PARTS UNDER AFORESAID CONDITIONS.

The purpose of the foregoing limitations on liability and Customer remedies is to protect Kärcher from unknown or undeterminable risks. Some states do not allow the exclusion or limitation of incidental or consequential damages, so the above limitation or exclusion may not apply to the Customer.

Kärcher sales and service representatives are not authorized to waive or alter the terms of this warranty, or to increase the obligations of Kärcher under the warranty.

Kärcher reserves the right to make design changes in any of its products without prior notification to the Customer.

